

Float Valves

Float Valves NV 16

Cast Steel Valve for High Flow Rates



Technical Data

Connection DN	15 - 100
Nominal Pressure PN	16 - 40
Operating Pressure	0 - 4 bar
K _{vs} -Value	2.6 - 80 m ³ /h
Temperature	130 °C
Medium	liquids

Description

Float valves automatically control liquid levels in sealed or open (non-pressurised) tanks and vessels without requiring external energy. The float registers the liquid level and directly controls the valve via a lever. A change in the liquid level immediately results in a changed flow volume.

NV 16 is a pipeline valve for horizontal or vertical flow. The standard soft seal ensures perfect sealing of the valve.

The valves are fitted with a float bar on which a float featuring an inner tube is mounted. By changing the position of the float on the bar the required liquid level is infinitely variable.

The following note applies to float valves fitted with float bars: If the liquid level is below the float bar i.e. if the float points downwards, a guide for the float bar should be installed.

When enquiring or ordering please quote the suffix letters given below:

- Z = inlet. Valve closes when float rises
 - A = outlet. Valve closes when float drops
 - w = horizontal flow
 - o = upward flow
 - u = downward flow
 - r = includes sealed spindle
- example: float valve Z/w (inlet valve for horizontal flow).

Standard

- » Float bar 1m length of stainless steel
- » Cylindrical float SC 8 stainless steel

Options

- » Float bar in special length
- » Rubber or plastic coating for corrosive media
- » Various seal materials suitable for your medium
- » Special versions on request

Please state working pressure range when enquiring or ordering.

Operating instructions, know how and safety instructions must be observed. The pressure has always been indicated as overpressure. We reserve the right to alter technical specifications without notice.



Pressure Ranges [bar] and K_{vs}-Values [m³/h]

press. range bar	nominal diameter DN								
	15	20	25	32	40	50	65	80	100
0 - 1	2.6	3.5	3.5	5.7	7.6	15	27	47	80
0 - 4	2.6	3.5	3.5	5.7	7.6	7.6	15	27	47

Float Valves

Float Valves NV 16

Cast Steel Valve for High Flow Rates



Materials

Body	cast steel optional CrNiMo-Steel
Cone and Seat	Cr-steel optional CrNiMo-steel
Cone Guide	CrNiMo-steel
Valve Seal	EPDM
Linkage	steel zincd or steel, optional CrNiMo-steel
Float Rod	CrNiMo-steel
Float	CrNiMo-steel

Dimensions [mm] PN 10/16*

size	nominal diameter DN								
	15	20	25	32	40	50	65	80	100
A*	130	150	160	180	200	230	290	310	350
B	175	175	175	195	195	195	290	290	290
C	55	55	55	125	125	125	105	105	105
D	360	360	360	480	480	480	640	640	640
E	270	270	270	360	360	360	480	480	480
F	315	315	315	420	420	420	560	560	560
G	45	45	45	60	60	60	80	80	80

* Overall length tolerances in acc. with DIN EN 558

Dimensions Cylindrical Float SC 8 [mm] (ø = height)*

press. range bar	nominal diameter DN								
	15	20	25	32	40	50	65	80	100
0 - 1	200	200	200	200	200	240	280	280	305
0 - 4	240	240	240	240	280	280	305	340	420

Weights [kg] PN 10/16*

pressure range bar	nominal diameter DN								
	15	20	25	32	40	50	65	80	100
0 - 1	7.4	8.4	9.4	12.4	15.4	21.3	43.2	51.2	63.8
0 - 4	8.3	9.3	10.3	13.3	17.2	22.2	43.8	52.7	67

*PN 25/40 on request

Customs Tariff Number

84818059

Special designs on request.

The pressure has always been indicated as overpressure.

Mankenberg reserves the right to alter or improve the designs or specifications of the products described herein without notice.

Dimensional Drawing

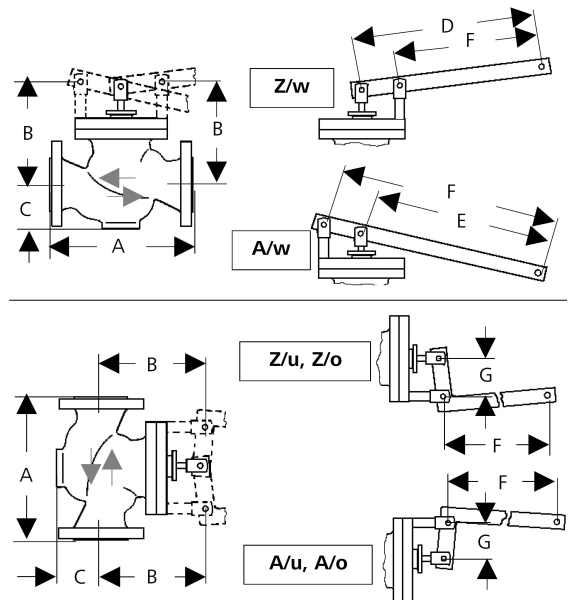

Authorised Distributor:



46, Jalan SS 22/21, Damansara Jaya,
47400 Petaling Jaya,
Selangor Darul Ehsan, Malaysia.

Email: nog@nog.com.my
Webste: www.nog.com.my