

# Float Valves

## Float Valves for Installation in Tanks ATHENA (NV 95e)



Epoxy-coated Valve for Potable Water

### Technical Data

Connection G	1 - 1 1/4
Nominal Pressure PN	16
Operating Pressure	0 - 16 bar
K <sub>vs</sub> -Value	10 m <sup>3</sup> /h
Temperature	70 °C
Medium	water, especially potable water

### Description

Float valves automatically control liquid levels in sealed or open (non-pressurised) tanks and vessels without requiring external energy. The float registers the liquid level and directly controls the valve via a lever. A change in the liquid level immediately results in a changed flow volume.

ATHENA (NV 95e) is a angle-type single-seat feed valve with relieved cone, the cone is fitted with a soft seal. The valves are approved for the use with potable water thanks to the coating of the body in accordance with the KTW guidelines.

The valve's compact design makes it suitable also for small vessels. The patented self-cleaning cone mechanism ensures reliable operation requiring low maintenance.

### Standard

- » Designed acc. to EN-1074/4
- » Body made of spheroidal cast iron GJS 450-10 with epoxy coating in blue RAL 5005, thickness min. 250 µm
- » Ball float made of polypropylene PP
- » Coating as per DVGW W270 and KTW recommendation of the German Ministry for Health

### Options

- » EPDM or FKM seals

Operating instructions, know how and safety instructions must be observed. The pressure has always been indicated as overpressure. We reserve the right to alter technical specifications without notice.



### K<sub>vs</sub> values [m<sup>3</sup>/h]

10

# Float Valves

## Float Valves for Installation in Tanks ATHENA (NV 95e)



Epoxy-coated Valve for Potable Water

Werkstoffe	
Body	spheroidal cast iron Epoxy-coated*
Cap	brass optional stainless steel 1.4301
Cone and seat	stainless steel 1.4301 optional 1.4404
Guide Ring	PTFE
Seals and O-Rings	NBR optional EPDM or FKM
Linkage	zinc-plated steel optional stainless steel 1.4404
Float	polyethylene PP

\* in accordance with KTW-recommendation and DVGW W270, thickness min. 250 µm

Weights [kg]
2.8

Customs Tariff Number
84818059

Special designs on request.  
The pressure has always been indicated as overpressure.  
Mankenberg reserves the right to alter or improve the designs or specifications of the products described herein without notice.

### Dimensional Drawing

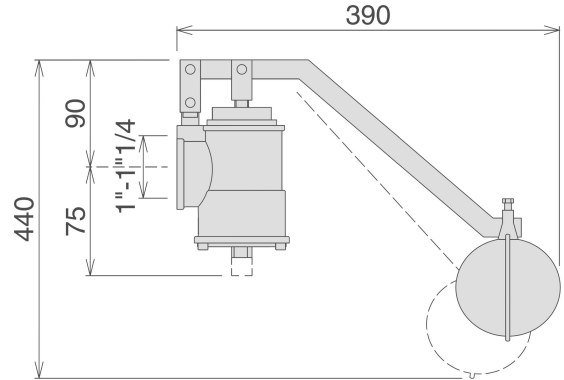

#### Authorised Distributor:



46, Jalan SS 22/21, Damansara Jaya,  
47400 Petaling Jaya,  
Selangor Darul Ehsan, Malaysia.

Email: [nog@nog.com.my](mailto:nog@nog.com.my)  
Webste: [www.nog.com.my](http://www.nog.com.my)