

Pipeline Ancillaries

Strainers and Filters SF 3.00

Strainer for Very High Pressures



Technical Data

Connection DN	15 - 100
Nominal Pressure PN	160 - 500
Temperature	550 °C
Medium	liquids gases and steam

Description

Strainers protect plant and equipment such as regulators, valves, measuring equipment against damage or operational failure caused by contamination. They are essential for start-up as well as continuous operation.

SF 3.00 is manufactured from forged steel and features a lenticular-section metallic body seal. The standard model has welding spigot connections. The flat stainless steel strainer mesh which is positioned perpendicular to the flow, and the straight-through flow result in a minimum pressure drop and a large sludge collecting chamber.

Cleaning is extremely simple and quick. Only the cover has to be removed for dismantelling.

Installation can be carried out in any position; installation with the cover at the bottom is recommended.

Standard

- » Welding spigots
- » Stainless steel mesh, mesh size 0.5 mm

Options

- » Strainer mesh sizes 0.25 mm, 1 mm or 2.5 mm
- » Special materials such as Duplex, Superduplex, Hastelloy® or titanium, others on request
- » Special connections: DIN-, ANSI or JIS flanges, other connections on request
- » Special versions on request

Operating instructions, know how and safety instructions must be observed. The pressure has always been indicated as overpressure. We reserve the right to alter technical specifications without notice.



Screen Netting

screen	light screen aperture mm	open screen area %
Nr. 3	0.25	41
Nr. 4	0.50	51
Nr. 5	1.0	67
Nr. 7	2.5	69

Pipeline Ancillaries

Strainers and Filters SF 3.00

Strainer for Very High Pressures



Materials

Nominal Pressure	PN 160 - 500			
Temperature	400 °C	450 °C	520 °C	550 °C
Body	C22.8	15Mo3	13CrMo44	
Seal	St 35.8	15Mo3	13CrMo44	10CrMo910
Screen	stainless steel			
Screen Frame	stainless steel			

Dimensions [mm]

PN	size	nominal diameter DN									
		15	20	25	32	40	50	65	80	100	
160	A*	125		165	165	180	180	205	250	280	
	B	45		65	80	75	100	105	105	130	
	C ₁	125		175	205	200	250	265	270	335	
	C ₂	150		205	240	240	285	305	310	375	
	ø E	130		170	170	190	190	220	270	300	
250	A*	125		175	175	190	190	225	250	280	
	B	45		70	80	80	100	115	110	135	
	C ₁	130		195	215	220	260	290	300	355	
	C ₂	165		230	255	265	300	330	350	400	
	ø E	130		180	180	200	200	240	270	305	
315	A*		140	175		200	200	225	260	285	
	B		62,5	70		82,5	100	112,5	110	140	
	C ₁		170	195		220	265	300	300	365	
	C ₂		205	235		270	310	350	350	415	
	ø E		145	180		210	210	245	280	315	
400	A*	130	145	185		205	195	230	270	295	
	B	45	65	70		82,5	95	115	110	140	
	C ₁	125	180	195		225	250	310	310	375	
	C ₂	160	220	230		275	295	355	365	430	
	ø E	135	150	190		215	205	250	290	320	
500	A*			195	185		200				
	B			70	75		100				
	C ₁			200	215		270				
	C ₂			245	255		310				
	ø E			200	190		210				

Dimensional Drawing

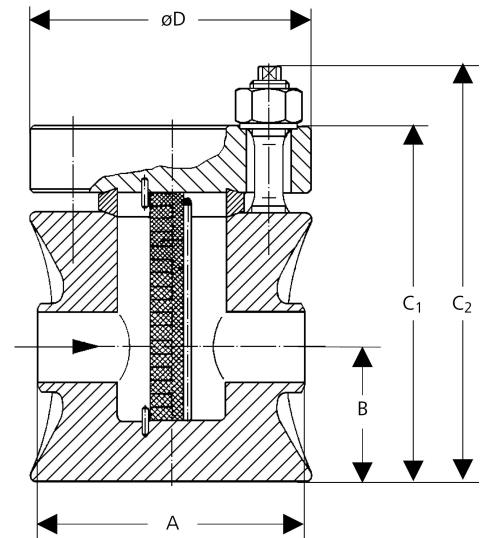

* Overall length tolerances in acc. with DIN EN 558

Weights [kg]

nominal pressure PN	nominal diameter DN									
	15	20	25	32	40	50	65	80	100	
160	9	16	25	31	35	42	65	90	130	
250	13	18	30	35	41	50	76	105	160	
315	15	22	33	38	48	58	85	110	175	
400	16	24	35	42	53	60	105	140	190	
500	18	28	37	45	55	63	115	150	250	

Customs Tariff Number

84818099

Special designs on request.

The pressure has always been indicated as overpressure.

Mankenberg reserves the right to alter or improve the designs or specifications of the products described herein without notice.

Authorised Distributor:



46, Jalan SS 22/21, Damansara Jaya,
47400 Petaling Jaya,
Selangor Darul Ehsan, Malaysia.

Email: nog@nog.com.my

Webste: www.nog.com.my