

# Pipeline Ancillaries

## Strainers and Filters SF 6.00

Stainless Steel Pot Strainer



### Technical Data

Connection DN	15 - 100
Connection G	1/2 - 2
Nominal Pressure PN	16
Temperature	130 °C
Medium	liquids, gases and steam

### Description

Strainers protect plant and equipment such as regulators, valves, measuring equipment against damage or operational failure caused by contamination. They are essential for start-up as well as continuous operation.

SF 6.00 is entirely manufactured from deep-drawn stainless steel featuring excellent corrosion resistance. The flat stainless steel strainer mesh which is positioned perpendicular to the flow, and the straight-through flow result in a minimum pressure drop and a large sludge collecting chamber.

Top and bottom sections of the valve body are connected by a clamp ring and two bolts. Servicing/maintenance is easy and does not call for special tooling.

Cleaning is extremely simple and quick. Only the cover has to be removed for dismantling.

Installation can be carried out in any position; installation with the cover at the bottom is recommended.

### Standard

- » All stainless steel construction
- » Strainer mesh size 0.5 mm
- » Quick-release body clamp ring

### Options

- » Strainer mesh sizes 0.25 mm, 1 mm or 2.5 mm
- » Various seal materials suitable for your medium
- » Special connections:
  - Aseptic, ANSI or DIN flanges, welding spigots; other connections on request
- » Special versions on request

Operating instructions, know how and safety instructions must be observed. The pressure has always been indicated as overpressure. We reserve the right to alter technical specifications without notice.



### Screen Netting

screen	light screen aperture mm	open screen area %
Nr. 3	0.25	41
Nr. 4	0.50	51
Nr. 5	1.0	67
Nr. 7	2.5	69

### Screen Plane cm<sup>2</sup>

nominal diameter		
DN 15 - 50	DN 65 - 80	DN 100
G 1/2 - 2	-	-
60	114	152

# Pipeline Ancillaries

## Strainers and Filters SF 6.00

### Stainless Steel Pot Strainer



Materials	
Body	CrNiMo-steel
Seal	EPDM
Screen	CrNiMo-steel
Screen Frame	CrNiMo-steel
Profile Clamp	CrNiMo-steel

Dimensions [mm]						
size	nominal diameter G					
	1/2	3/4	1	1 1/4	1 1/2	2
A <sub>1</sub> *	110	110	110	110	110	160
B	105	105	105	105	105	105
C	155	155	155	155	155	155
D	140	140	140	140	140	140

\* Overall length tolerances in acc. with DIN EN 558

Weights [kg]						
nominal diameter G						
1/2	3/4	1	1 1/4	1 1/2	2	
1.2	1.4	1.4	1.6	1.6	2.3	

Dimensions [mm]									
size	nominal diameter DN								
	15	20	25	32	40	50	65	80	100
A <sub>2</sub> *	180	180	180	180	200	230	290	310	350
B	108	108	108	108	108	108	148	148	207
C	157	157	157	157	157	157	212	212	270
D	140	140	140	140	140	140	200	200	200

\* Overall length tolerances in acc. with DIN EN 558

Weights [kg]									
nominal diameter DN									
15	20	25	32	40	50	65	80	100	
2.6	3.2	3.6	5	5.1	6.3	9.4	10.7	13.5	

Customs Tariff Number
84818099

Special designs on request.  
The pressure has always been indicated as overpressure.  
Mankenberg reserves the right to alter or improve the designs or specifications of the products described herein without notice.

### Dimensional Drawing

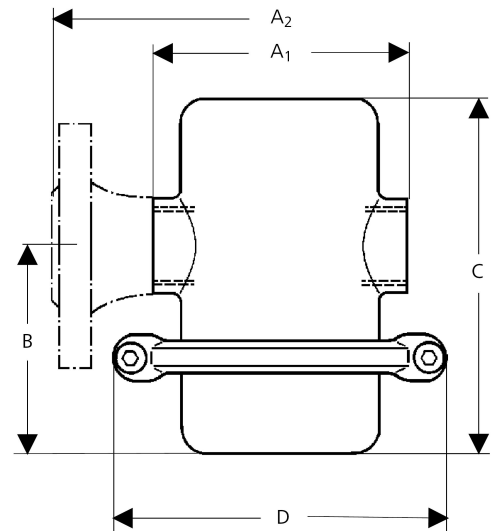

#### Authorised Distributor:



46, Jalan SS 22/21, Damansara Jaya,  
47400 Petaling Jaya,  
Selangor Darul Ehsan, Malaysia.

Email: [nog@nog.com.my](mailto:nog@nog.com.my)  
Webste: [www.nog.com.my](http://www.nog.com.my)