

PENBERTHY MODELS RHR AND THR DIRECT READING LIQUID LEVEL GAUGES

High pressure flat glass gauges in reflex and transparent styles



THR

FEATURES

- Reliable, easy to understand level reference.
- Gives users the ability to inspect liquid characteristics visually (transparent style).
- Non-intrusive
- Operation is independent of most liquid characteristics. Multiple liquids can be processed through the same vessel without concerns for density, surface turbulence, dielectric conductivity etc.
- No electrical power required. Provide accurate direct liquid level measurement in remote locations where power is not available. Not affected by power failures.
- Suitable for full vacuum applications.
- Up to a 4 section size 9 (60.875" of visible range).
- Optional offshore coating ideal cost-effective solution for corrosive offshore environments.
- NACE materials available for sour gas service, both wetted and environmental.
- Used for verification of other level instrument technology.
- Optional shields available to prolong glass life in corrosive environments (transparent style only).
- High pressure design to allow for maximum pressure regardless of glass size.
- Recessed gasket seat in chamber and cover.

GENERAL APPLICATION

High pressure gauges are designed to be used in direct reading liquid level measurement for high pressure tank applications in the petroleum, chemical, natural gas and general process industries.

TECHNICAL DATA

Materials: Carbon or stainless steel cover and chamber options. Constructed with IFG-5500 gaskets, with options for Grafoil or GoreGR. Tempered Borosilicate glass rated to 600°F

Glass size: 1 through 9

Visible length: 3.625" to 60.875" (92mm to 1546mm)

Connections: End or side; threaded, socketweld or flanged

Pressure ratings (max)

RHR/THR: up to 5000 psig (344.7 barg)

Temperature range: -20° to 800°F (-29° to 427°C)

For temperatures above 800°F (427°C) Aluminosilicate Glass must be used.

PENBERTHY®

16633 Foltz Parkway, Strongsville, OH 44149 USA • Telephone: +440-572-1500
www.PenberthyProcess.com • sales@PenberthyProcess.com

OVERVIEW

RHR and THR gauges provide optimum versatility and can be used for most offshore applications and in other corrosive environments. They resist torsional stresses exceptionally well to provide a process gauge for the most demanding applications. These gauges are designed for high pressure service. Process liquid levels are observed through the glass as it rises and falls in the gauge chamber.

Optional materials are available for temperature ranges -325°F to 800°F (198°C to 427°C).

Models RHR – Reflex style gauges

Reflex style gauges have a single vision slot through which light can enter the gauge chamber to determine the liquid level. Above the liquid level, glass prisms reflect the surrounding light back to the observer appearing silvery. Below the liquid level, the liquid fills the prisms causing the glass to become relatively transparent, typically appearing dark to the observer. An opaque liquid such as milk would reflect the light directly at the surface of the prisms, where it appears as a solid column of white.

The interface between the liquid and gas occurs where the silvery and dark/opaque area intersect. The RHR model gauges are designed for high pressure applications but low thermal cycle duty.

Models THR – Transparent style gauges

Transparent style gauges have a vision slot on both sides of the chamber. Light enters the gauge from the side opposite the observer so that both the level of a liquid and its characteristics can be seen. Illuminators are available for use with transparent gauges for easier liquid observation in dark environments and are available with optional Aluminosilicate glass rated to maximum 800°F (427°C).

THR gauges may be used for interface applications.

The THR model gauges are designed for high pressure applications but low thermal cycle duty.

REFLEX

(Model RL shown for illustrative purposes only)



TRANSPARENT

(Model TL shown for illustrative purposes only).



PENBERTHY MODELS RHR AND THR DIRECT READING LIQUID LEVEL GAUGES
 DIMENSIONS – END CONNECTED

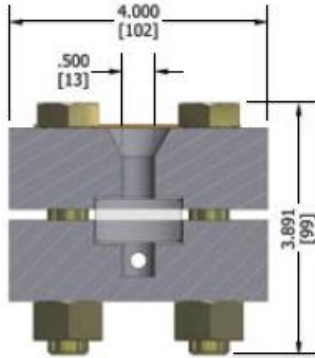

Series RHR Reflex

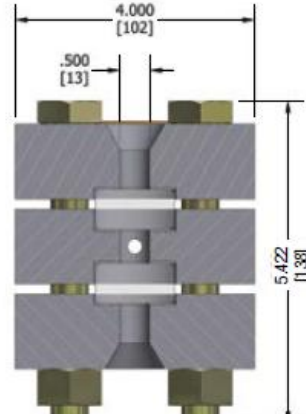

Series THR Transparent

Sect. X Size	Visible Range		Overall Length (End Connected Gauge Only)		Approximate Weight			
	in	mm	in	mm	Reflex, R-40		Transp, T-40	
					lbs.	Kgs	lbs.	Kgs
SINGLE-SECTION GAUGES								
11	3.625	92	7.250	184	20	9.1	28	12.7
12	4.625	117	8.250	210	22	10.0	32	14.5
13	5.625	143	9.250	235	25	11.4	35	15.9
14	6.625	168	10.250	260	27	12.3	38	17.3
15	7.750	197	11.375	289	30	13.6	42	19.1
16	9.000	229	12.625	321	34	15.5	47	21.4
17	10.125	257	13.750	349	37	16.8	52	23.6
18	11.750	298	15.375	391	41	18.6	57	25.9
19	12.500	318	16.125	410	43	19.5	60	27.3
TWO-SECTION GAUGES								
23	14.875	378	18.500	470	50	22.7	70	31.8
24	16.875	429	20.500	521	54	24.5	76	34.5
25	19.125	486	22.750	578	60	27.3	84	38.2
26	21.625	549	25.250	641	68	30.9	94	42.7
27	23.875	606	27.500	699	74	33.6	104	47.3
28	27.125	689	30.750	781	82	37.3	114	51.8
29	28.625	727	32.250	819	86	39.1	120	54.5
THREE-SECTION GAUGES								
36	34.250	870	37.875	962	102	46.4	141	64.1
37	37.625	956	41.250	1048	111	50.5	156	70.9
38	42.500	1080	46.125	1175	123	55.9	171	77.7
39	44.750	1137	48.375	1229	129	58.6	180	81.8
FOUR-SECTION GAUGES								
47	51.375	1305	55.000	1397	148	67.3	208	94.5
48	57.875	1470	61.500	1562	164	74.5	228	103.6
49	60.875	1546	64.500	1638	172	78.2	240	109.1

PENBERTHY MODELS RHR AND THR DIRECT READING LIQUID LEVEL GAUGES
 PRESSURE/TEMPERATURE RATINGS – MODELS RH/RHR

RHR/THR (PSI)		
Temperature		CS & 316SS
°F	°C	
100	38	5000
200	93	4685
300	149	4370
400	204	4055
500	260	3740
600	316	3425
For temperatures above 600°F (427°C) Aluminosilicate Glass must be used		
700	371	3110
800	427	2795

Saturated Steam Rating 1500 WSP

RHR/THR (BarG)		
Temperature		CS & 316SS
°F	°C	
100	38	344.7
200	93	323.0
300	149	301.3
400	204	279.6
500	260	257.9
600	316	236.1
For temperatures above 600°F (427°C) Aluminosilicate Glass must be used		
700	371	214.4
800	427	192.7

Saturated Steam Rating 1500 WSP

TEST PRESSURE: All gauges are hydrostatically tested by Penberthy prior to shipment @ 1-1/2 times the design pressure rating at 100°F (38°C).

PENBERTHY MODELS RHR AND THR DIRECT READING LIQUID LEVEL GAUGES
 MATERIAL SPECIFICATIONS – MODELS RHR/THR

Description	Carbon Steel	316SS Wetted	All 316SS
Cover		A108 Gr.1018	A240
Chamber		A108 Gr.1018	A240
Stud	A193 Gr.B7 (Yellow Zn Plated)		A193 Gr.B8M
Nut	A194 Gr.2H (Yellow Zn Plated)		A194 Gr.8M
Sal Gasket		IFG5500 (Optional Grafoil or GoreGr)	
Cusion Gasket			
Shield		None (Optional Mica, PCTFE (302F))	
Glass		Reflex or Transparent	
U-Bolt	A193 Gr.B7 (Yellow Zn Plated)		A93 Gr.B8M

Contact Factory for special alloy chambers, covers, bolting

Optional Accessories

- Illuminator
- Spring Washers
- Heat Tracing
- Scale
- Support Bracket
- Insulation Jackets

PENBERTHY MODELS RHR AND THR DIRECT READING LIQUID LEVEL GAUGES
ORDERING INFORMATION – PART 1

SELECTION GUIDE

Example: 4 RHR 7 C C C X C B X

- No. of sections**
01 1 Section
02 2 Section
03 3 Section
04 4 Section

- Gage type**
RHR HP Reflex gage with recessed gasket chamber and cover
THR HP Transparent gage with recessed gasket chamber and cover

- Glass size**
1 Size 1
2 Size 2
3 Size 3
4 Size 4
5 Size 5
6 Size 6
7 Size 7
8 Size 8
9 Size 9

- Wetted parts material (chamber)**
C Carbon steel (standard)
S 316/316L Stainless steel

- Cover material**
C Carbon steel (standard)
S 316/316L Stainless steel

- Boltina material**
C STL A193 Gr.B7 (Yellow Zn Plated)/A194 2H (standard)
S SST A193 B8M/A194 8M

- NACE MR-01-75 and/or MR-01-03**
X None
W NACE wetted
E Environmental

PART 2 - PAGE 7

C B X

PART 3 - PAGE 8

X X X X X

PART 4 - PAGE 9

S B S B X X X X

PENBERTHY MODELS RHR AND THR DIRECT READING LIQUID LEVEL GAUGES
ORDERING INFORMATION – PART 2

PART 1 - PAGE 6

SELECTION GUIDE - PART 2

PART 3 - PAGE 8

4 RHR 7 C C C X **Example:** C B X X X X X X

End connection size

- C 1/2" (Standard)
- E 3/4" (flange only)
- F 1" (flange only)
- G 1-1/4" (flange only)
- H 1-1/2" (flange only)
- J 2" (flange only)

End connection type

- B NPT female (standard)
- D Socketweld female
- N Raised face SO
- P Flat face SO
- R RTJ SO
- S Raised face SW
- T Flat face SW
- U RTJ SW
- V Raised face WN
- W Flat face WN
- Y RTJ WN
- F Vent and drain plugged
- G Drain plugged
- H Vent plugged
- J Socketweld male

End connection pressure class

- X None
- 1 150#
- 3 300#
- 6 600#
- 9 900#
- F 1500#
- T 2500#

PART 4 - PAGE 9
 S B S B X X X X



PENBERTHY MODELS RHR AND THR DIRECT READING LIQUID LEVEL GAUGES
ORDERING INFORMATION – PART 3

PART 1 - PAGE 6

4 RHR 7 C C C X

SELECTION GUIDE - PART 3

Example: X X X X X S B S B X X X X

PART 2 - PAGE 7

C B X

Side connection size	
X	None
C	1/2" (standard)
E	3/4" (flange only)
F	1" (flange only)
G	1-1/4" (flange only)
H	1-1/2" (flange only)
J	2" (flange only)
Side connection type	
X	None
B	NPT female (standard)
D	Socketweld female
M	NPT male
N	Raised face SO
P	Flat face SO
R	RTJ SO
S	Raised face SW
T	Flat face SW
U	RTJ SW
V	Raised face WN
W	Flat face WN
Y	RTJ WN
Side connection pressure class	
X	None
1	150#
3	300#
6	600#
9	900#
F	1500#
T	2500#
Side connection location	
X	None
S	Right side connected (standard)
L	Left side connected
B	Back connected
Connection dimension	
X	None
00000	Inches (first 3 digits = number of whole inches, last 2 digits = fraction of an inch in hundredths)

PART 1 - PAGE 6

4 RHR 7 C C C X

PART 2 - PAGE 7

C B X

PART 3 - PAGE 8

X X X X X

SELECTION GUIDE - PART 4

Example:	S	S	S	B	X	X	X
Gasket material							
S Grafoil/SS insert (standard)							
T ePTFE (GoreGR®)							
Cushion Material							
S Grafoil/SS insert							
A Garlock IFG-5500							
Paint specification							
X None							
S Standard							
O Offshore Paint							
Option 1							
X None							
B 1 Welded support bracket							
C 2 Welded support brackets							
D 3 Welded support brackets							
K Belleville washers							
Option 2							
X None							
Option 3							
X None							
B Mica Shields V2/V4 (.005-.007" thick)							
C PCTFE shields (KEL-F)							
Option 4							
X None							
N Aluminosilicate glass							

Authorised Distributor:



**NATIONWIDE
OIL & GAS**

46, Jalan SS 22/21, Damansara Jaya,
47400 Petaling Jaya,
Selangor Darul Ehsan, Malaysia.
Email: nog@nog.com.my
Website: www.nog.com.my

PENBERTHY®

16633 Foltz Parkway, Strongsville, OH 44149 USA • Telephone: +440-572-1500
www.PenberthyProcess.com • sales@PenberthyProcess.com