

# PENBERTHY MODELS RL AND TL DIRECT READING LIQUID LEVEL GAUGES

Low pressure flat glass gauges in reflex and transparent styles



## FEATURES

- Reliable, easy to understand level reference.
- Gives users the ability to inspect liquid characteristics visually (transparent style).
- Non-intrusive.
- Operation is independent of most liquid characteristics. Multiple liquids can be processed through the same vessel without concerns for density, surface turbulence, dielectric conductivity etc.
- No electrical power required. Provide accurate direct liquid level measurement in remote locations where power is not available. Not affected by power failures.
- Suitable for full vacuum applications.
- Provide a near-unlimited length of measure.
- Optional offshore coating 2600 protection; ideal cost-effective solution for corrosive offshore environments.
- NACE wetted materials available for sour gas service.
- Used for verification of other level instrument technology.
- Standard flat gasket seat allows easy removal of gasket residue during rebuild.
- Optional shields available to prolong glass life in corrosive environments (transparent style only).
- Cross ties between vision slots in transparent style gauges provide higher strength chamber due to reduction of unsupported beam length.
- FM approved

## GENERAL APPLICATION

Low pressure direct reading liquid level measurement applications in the petroleum, chemical and general process industries. They are not recommended for steam/water applications.

## TECHNICAL DATA

Materials:	Ductile iron cover; carbon steel or stainless steel chamber; Grafoil/Mylar gaskets and cushions; Tempered Borosilicate glass rated to 600°F
Glass size:	1 through 9
Visible length:	3¾" to 139¾" (95 to 3550 mm)
Connections:	End or side; threaded, socketweld or flanged
Pressure ratings (max):	
RL:	Glass size 1: 2400 psig (165 barg) Glass size 9: 1800 psig (124 barg)
TL:	Glass size 1: 2000 psig (138 barg) Glass size 9: 500 psig (34 barg)
Temperature range*:	-20° to 600°F (-29° to 316°C)

\* Non-steam/water applications

# PENBERTHY®

16633 Foltz Parkway, Strongsville, OH 44149 USA • Telephone: +440-572-1500  
[www.PenberthyProcess.com](http://www.PenberthyProcess.com) • [sales@PenberthyProcess.com](mailto:sales@PenberthyProcess.com)

# PENBERTHY MODELS RL AND TL DIRECT READING LIQUID LEVEL GAUGES

## OVERVIEW

### OVERVIEW

RL and TL gauge models are designed to maximize the mechanical and economic advantages of ductile iron covers and are used in less demanding process applications. Process liquid levels are observed through the glass as it rises and falls in the gauge chamber.

#### Models RL – Reflex style gauge

Reflex style gauges have a single vision slot through which light can enter the gauge chamber to determine liquid level. Above the liquid level, glass prisms reflect the surrounding light back to the observer appearing silvery. Below the liquid level, the liquid fills the prisms causing the glass to become relatively transparent, typically appearing dark to the observer. An opaque liquid such as milk would reflect the light directly at the surface of the prisms, where it appears as a solid column of white.

The interface between the liquid and gas occurs where the silvery and dark/opaque area intersect.

#### Model TL – Transparent style gauge

Transparent style gauges have a vision slot on both sides of the chamber. Light enters the gauge from the side opposite the observer so that both the level of a liquid and its characteristics can be seen. Illuminators are available for use with transparent gauges for easier liquid observation in dark environments.

Transparent gauges may be used for interface applications

MODEL RL - REFLEX



MODEL TL - TRANSPARENT



**PENBERTHY MODELS RL AND TL DIRECT READING LIQUID LEVEL GAUGES**  
**DIMENSIONS - END CONNECTED**

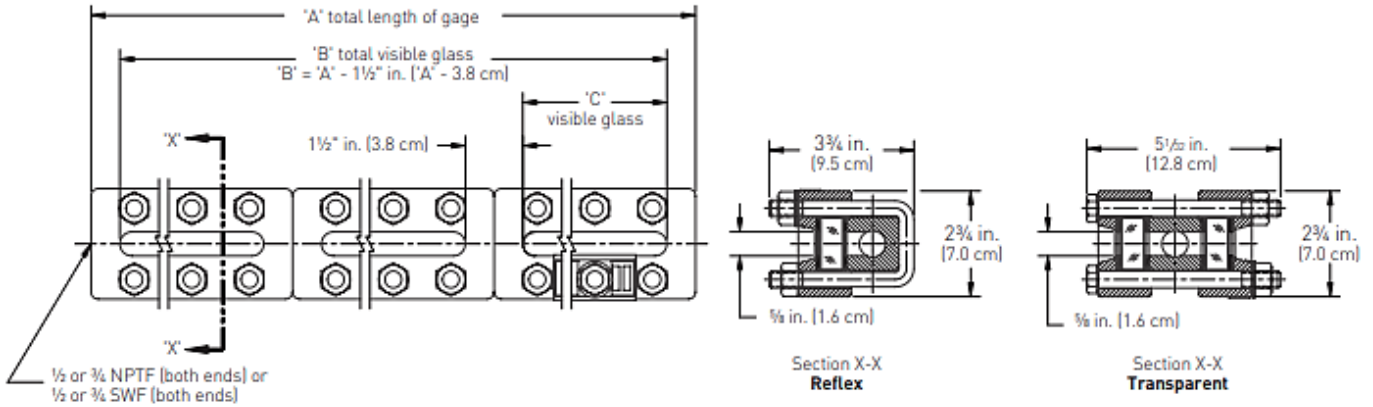

**DIMENSIONS - END CONNECTED**

Glass size	Dim 'C' in inches (cm)	Dimension 'A' (overall length) in inches (cm)										Quantity per section (reflex)		Quantity per section (transparent)		
		Number of sections										Bolt	Nut	Bolt	Nut	
		1	2	3	4	5	6	7	8	9	10					
1	3.75 (9.5)	5.25 (13.3)											3	6	6	6
2	4.75 (12.1)	6.25 (15.9)											3	6	6	6
3	5.75 (14.6)	7.25 (18.4)											4	8	8	8
4	6.75 (17.1)	8.25 (21.0)	16.50 (41.9)										5	10	10	10
5	7.87 (20.0)	9.37 (23.8)	18.75 (47.6)										5	10	10	10
6	9.12 (23.2)	10.62 (27.0)	21.25 (54.0)	31.87 (81.0)									6	12	12	12
7	10.25 (26.0)	11.75 (29.8)	23.50 (59.7)	35.25 (89.5)	47 (119.4)	58.75 (149.2)							7	14	14	14
8	11.87 (30.2)	13.37 (34.0)	26.75 (67.9)	40.12 (101.9)	53.50 (135.9)	66.87 (169.9)	80.25 (203.8)	93.62 (237.8)	107 (271.8)	120.37 (305.8)	133.75 (339.7)		7	14	14	14
9	12.62 (32.1)	14.12 (35.9)	28.25 (71.8)	42.37 (107.6)	56.50 (143.5)	70.62 (179.4)	84.75 (215.3)	98.87 (251.1)	113 (287.0)	127.12 (322.9)	141.25 (358.8)		8	16	16	16

**PENBERTHY MODELS RL AND TL DIRECT READING LIQUID LEVEL GAUGES**  
**DIMENSIONS - SIDE CONNECTED**

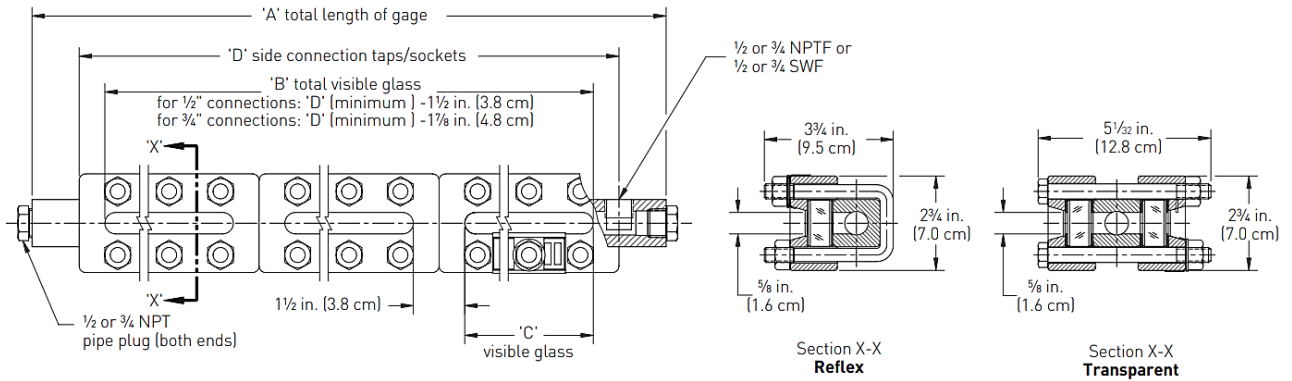

**DIMENSIONS - SIDE CONNECTED**

Max. and min. dimension 'D' in inches (cm) for 1/2" NPT/socketweld connections										
Centers available in 1/8" (0.3 cm) increments between max. and min. / Standard side connection is to the right of the gage vision										
Glass size	Number of sections									
	1	2	3	4	5	6	7	8	9	10
1 min.	5.25 [13.3]									
1 max.	7.62 [19.4]									
2 min.	6.25 [15.9]									
2 max.	8.62 [21.9]									
3 min.	7.25 [18.4]									
3 max.	9.62 [24.4]									
4 min.	8.25 [21.0]	16.50 [41.9]								
4 max.	10.75 [27.3]	20.12 [51.1]								
5 min.	9.37 [23.8]	18.75 [47.6]								
5 max.	12.00 [30.5]	22.62 [57.5]								
6 min.	10.62 [27.0]	21.25 [54.0]	31.87 [81.0]							
6 max.	13.12 [33.3]	24.87 [63.2]	36.62 [93.0]							
7 min.	11.75 [29.8]	23.50 [59.7]	35.25 [89.5]	47.00 [119.4]	58.75 [149.2]					
7 max.	14.75 [37.5]	28.12 [71.4]	41.25 [104.8]	54.87 [139.4]	68.25 [173.4]					
8 min.	13.37 [34.0]	26.75 [67.9]	40.12 [101.9]	53.50 [135.9]	66.87 [169.9]	80.25 [203.8]	93.62 [237.8]	107.00 [271.8]	120.37 [305.7]	133.75 [339.7]
8 max.	15.50 [39.4]	29.62 [75.2]	43.75 [111.1]	57.87 [147.0]	72.00 [182.9]	84.62 [214.9]	98.75 [250.8]	112.87 [286.7]	127.00 [322.6]	141.12 [358.5]
9 min.	14.12 [35.9]	28.25 [71.8]	42.37 [107.6]	56.50 [143.5]	70.62 [179.4]	84.75 [215.3]	98.87 [251.1]	113.00 [287.0]	127.12 [322.9]	141.25 [358.8]
9 max.	17.87 [45.4]	33.25 [84.5]	48.37 [122.9]	60.12 [152.7]	81.62 [207.3]	93.50 [237.5]	106.87 [271.5]	120.25 [305.4]	133.62 [339.4]	147.00 [373.4]

**NOTES**

1. For minimum 3/4" NPT/socketweld connections - add 3/8" (1.0 cm) to dimension 'D' shown above.
2. For maximum 3/4" NPT/socketweld connections - subtract 3/4" (1.9 cm) from dimension 'D' shown above.
3. Consult factory for minimum front or back connections

Glass size	Dim 'C' in inches (cm)	Dimension 'A' in inches (cm) 1/2" and 3/4" NPT/socketweld connections										Quantity per section (reflex)		Quantity per section (transparent)	
		Number of sections										Bolt	Nut	Bolt	Nut
		1	2	3	4	5	6	7	8	9	10				
1	3.75 [9.5]	10.37 [26.4]										3	6	6	6
2	4.75 [12.1]	11.37 [28.9]										3	6	6	6
3	5.75 [14.6]	12.37 [31.4]										4	8	8	8
4	6.75 [17.1]	13.50 [34.3]	22.87 [58.1]									5	10	10	10
5	7.87 [20.0]	14.75 [37.5]	25.37 [64.5]									5	10	10	10
6	9.12 [23.2]	15.87 [40.3]	27.62 [70.2]	39.37 [100.0]								6	12	12	12
7	10.25 [26.0]	17.50 [44.5]	30.87 [78.4]	44.25 [112.4]	57.62 [146.4]	71.00 [180.3]						7	14	14	14
8	11.87 [30.2]	18.25 [46.4]	32.37 [82.2]	46.50 [118.1]	60.62 [154.0]	74.75 [189.9]	***	***	***	***	***	7	14	14	14
9	12.62 [32.1]	20.62 [52.4]	36.00 [91.5]	51.12 [129.9]	62.87 [159.7]	84.37 [214.3]	***	***	***	***	***	8	16	16	16

**NOTES**

1. \*\*\* For 1/2" NPT or socketweld connections: Dimension 'D' + 2 3/4" (7.0 cm)
2. \*\*\* For 3/4" NPT or socketweld connections: Dimension 'D' + 3 1/2" (8.9 cm)



# PENBERTHY MODELS RL AND TL DIRECT READING LIQUID LEVEL GAUGES PRESSURES/TEMPERATURES

## RL - PRESSURE/TEMPERATURE RATINGS using standard gasket material<sup>[1]</sup>

Glass size	Max. working pressure psig (kPa) at temperatures up to:						
	100°F ( 38°C)	200°F ( 93°C)	250°F (121°C)	300°F (149°C)	400°F (204°C)	500°F (260°C)	600°F (316°C)
1	2400 (16550)	2320 (16000)	2280 (15720)	2240 (15440)	2150 (14820)	2000 (13790)	1780 (12270)
2	2335 (16100)	2250 (15510)	2210 (15240)	2170 (14960)	2080 (14340)	1940 (13380)	1720 (11860)
3	2250 (15510)	2180 (15030)	2140 (14750)	2100 (14480)	2020 (13930)	1880 (12960)	1670 (11510)
4	2175 (15000)	2100 (14480)	2060 (14200)	2020 (13930)	1940 (13380)	1820 (12550)	1600 (11030)
5	2100 (14480)	2030 (14000)	1995 (13750)	1960 (13510)	1880 (12960)	1750 (12070)	1550 (10690)
6	2025 (13960)	1950 (13440)	1920 (13240)	1890 (13030)	1810 (12480)	1680 (11580)	1500 (10340)
7	1950 (13440)	1890 (13030)	1855 (12790)	1820 (12550)	1750 (12070)	1630 (11240)	1440 (9930)
8	1875 (12930)	1820 (12550)	1785 (12310)	1750 (12070)	1680 (11580)	1560 (10760)	1390 (9580)
9	1800 (12410)	1740 (12000)	1710 (11790)	1680 (11580)	1620 (11170)	1510 (10410)	1340 (9240)

### NOTE

- Optional gasket material may result in a de-rated maximum pressure for the gage.

## RL<sup>2</sup> - PRESSURE/TEMPERATURE RATINGS using standard gasket material<sup>[1]</sup> and steel MR0175/MR0103 NACE bolting

Glass Size	Max. working pressure psig (kPa) at temperatures up to:						
	100°F ( 38°C)	200°F ( 93°C)	250°F (121°C)	300°F (149°C)	400°F (204°C)	500°F (260°C)	600°F (316°C)
1	2160 (14890)	2090 (14410)	2050 (14130)	2015 (13890)	1935 (13340)	1800 (12410)	1600 (11030)
2	2100 (14480)	2025 (13960)	1990 (13720)	1955 (13480)	1870 (12890)	1745 (12030)	1550 (10690)
3	2025 (13960)	1960 (13510)	1925 (13270)	1890 (13030)	1820 (12550)	1690 (11650)	1505 (10380)
4	1960 (13510)	1890 (13030)	1855 (12790)	1820 (12550)	1745 (12030)	1640 (11310)	1440 (9930)
5	1890 (13030)	1825 (12580)	1795 (12380)	1765 (12170)	1690 (11650)	1575 (10860)	1395 (9620)
6	1825 (12580)	1755 (12100)	1730 (11930)	1700 (11720)	1630 (11240)	1510 (10410)	1350 (9310)
7	1755 (12100)	1700 (11720)	1670 (11510)	1640 (11310)	1575 (10860)	1465 (10100)	1295 (8930)
8	1690 (11650)	1640 (11310)	1605 (11070)	1575 (10860)	1510 (10410)	1405 (9690)	1250 (8620)
9	1620 (11170)	1565 (10790)	1540 (10620)	1510 (10410)	1460 (10070)	1360 (9380)	1205 (8310)

## RL<sup>2</sup> - PRESSURE/TEMPERATURE RATINGS using standard gasket material<sup>[1]</sup> and stainless steel MR0175/MR0103 NACE bolting

Glass size	Max. working pressure psig (kPa) at temp. up to:
	100°F (38°C)
1	1930 (13310)
2	1560 (10760)
3	1730 (11930)
4	1860 (12820)
5	1605 (11070)
6	1670 (11510)
7	1745 (12030)
8	1515 (10450)
9	1630 (11240)

### NOTES

- Optional gasket material may result in a derated maximum pressure for the gage.
- Not to be used for Environmental NACE applications.

# PENBERTHY MODELS RL AND TL DIRECT READING LIQUID LEVEL GAUGES PRESSURES/TEMPERATURES

## TL - PRESSURE/TEMPERATURE RATINGS using standard gasket material<sup>[1]</sup>

Glass size	Max. working pressure psig (kPa) at temperatures up to:						
	100°F (38°C)	200°F (93°C)	250°F (121°C)	300°F (149°C)	400°F (204°C)	500°F (260°C)	600°F (316°C)
1	2000 (13790)	1930 (13310)	1900 (13100)	1870 (12890)	1790 (12340)	1660 (11450)	1480 (10200)
2	1815 (12510)	1750 (12070)	1720 (11860)	1690 (11650)	1620 (11170)	1510 (10410)	1340 (9240)
3	1630 (11240)	1580 (10890)	1550 (10690)	1520 (10480)	1460 (10070)	1360 (9380)	1210 (8340)
4	1440 (9930)	1390 (9580)	1365 (9410)	1340 (9240)	1290 (8890)	1200 (8270)	1060 (7310)
5	1250 (8620)	1210 (8340)	1190 (8200)	1170 (8070)	1120 (7720)	1040 (7170)	920 (6340)
6	1065 (7340)	1030 (7100)	1015 (7000)	995 (6860)	950 (6550)	890 (6140)	790 (5450)
7	875 (6030)	845 (5830)	830 (5720)	815 (5620)	785 (5410)	730 (5030)	645 (4450)
8	690 (4760)	665 (4580)	655 (4520)	645 (4450)	620 (4270)	575 (3960)	510 (3520)
9	500 (3450)	480 (3310)	475 (3270)	465 (3210)	445 (3070)	415 (2860)	370 (2550)

### NOTE

1. Optional gasket material may result in a de-rated maximum pressure for the gage.

## TL<sup>2</sup> - PRESSURE/TEMPERATURE RATINGS using standard gasket material<sup>[1]</sup> and steel MR0175/MR0103 NACE bolting

Glass size	Max. working pressure psig (kPa) at temperatures up to:						
	100°F (38°C)	200°F (93°C)	250°F (121°C)	300°F (149°C)	400°F (204°C)	500°F (260°C)	600°F (316°C)
1	1800 (12410)	1735 (11960)	1710 (11790)	1685 (11620)	1610 (11100)	1495 (10310)	1330 (9170)
2	1635 (11270)	1575 (10860)	1550 (10690)	1520 (10480)	1460 (10070)	1360 (9380)	1205 (8310)
3	1465 (10100)	1420 (9790)	1395 (9620)	1370 (9450)	1315 (9070)	1225 (8450)	1090 (7520)
4	1295 (8930)	1250 (8620)	1230 (8480)	1205 (8310)	1160 (8000)	1080 (7450)	955 (6580)
5	1125 (7760)	1090 (7520)	1070 (7380)	1055 (7270)	1010 (6960)	935 (6450)	830 (5720)
6	960 (6620)	925 (6380)	915 (6310)	895 (6170)	855 (5890)	800 (5520)	710 (4900)
7	790 (5450)	760 (5240)	745 (5140)	735 (5070)	705 (4860)	655 (4520)	580 (4000)
8	620 (4270)	600 (4140)	590 (4070)	580 (4000)	560 (3860)	520 (3590)	460 (3170)
9	450 (3100)	430 (2960)	425 (2930)	420 (2900)	400 (2760)	375 (2590)	335 (2310)

## TL<sup>2</sup> - PRESSURE/TEMPERATURE RATINGS using standard gasket material<sup>[1]</sup> and stainless steel MR0175/MR0103 NACE bolting

Glass size	Max. working pressure psig (kPa) at temp. up to:
	100°F (38°C)
1	1880 (12960)
2	1510 (10410)
3	1630 (11240)
4	1440 (9930)
5	1250 (8620)
6	1065 (7340)
7	875 (6030)
8	690 (4760)
9	500 (3450)

## TL - PRESSURE/TEMPERATURE RATINGS using standard gasket material<sup>[1]</sup> and aluminosilicate glass

Glass size	Max. working pressure psig (kPa) at temp. up to:
	600°F (316°C)
1	1480 (10200)
2	1340 (9240)
3	1210 (8340)
4	1060 (7310)
5	920 (6340)
6	790 (5450)
7	645 (4450)
8	510 (3520)
9	370 (2550)

### NOTES

1. Optional gasket material may result in a derated maximum pressure for the gage.
2. Not to be used for Environmental NACE applications.

**PENBERTHY MODELS RL AND TL DIRECT READING LIQUID LEVEL GAUGES**  
**MATERIAL SPECIFICATIONS**

**MATERIAL SPECIFICATIONS**

Ref. no.	Description	Standard materials			Optional materials
		Carbon steel to -20°F	STS wetted to -20°F	Sour gas service to -20°F	
1	Cover		ASTM A395 ductile iron		ASTM A123 galvanized ductile iron
2	Chamber	ASTM A105 (forged) carbon steel	ASTM A276 316/316L STS	ASTM A105 (forged) carbon steel per NACE MR0175 and/OR MR0103	ASTM A276 304/304L STS ASTM A276 Duplex 2205 STS ASTM B164 Monel® 400 ASTM B463 Alloy 20 (CARP 20 Cb3)® ASTM B335 Hastelloy B® ASTM B575 Hastelloy C® 276 ASTM A123 galvanized steel
4	Nut		ASTM A194 carbon steel Gr. 2 or 2H		ASTM A194 Gr. 8M 316 STS ASTM A153 galvanized steel
7	Gasket		Grafoil® Gr. GHP w/polyester (Mylar) insert		Nobestos® D7301 Garlock® 3000, 3100, 3200, 3300, 5500 PCTFE (replaces Kel-F®) Gylon® 3500, 3504, 3510 PTFE (25% glass filled, virgin) Grafoil® Gr. GHR w/316 STS insert Buna-N NBR Neoprene® Viton® consult factory for others
8	Cushion		Grafoil® Gr. GHP w/polyester (Mylar) insert		Nobestos® D7301 Garlock® 3000, 3100, 3200, 3300, 5500 PCTFE (replaces Kel-F®) Gylon® 3500, 3504, 3510 PTFE (25% glass filled, virgin) Grafoil® Gr. GHR w/316 STS insert Buna-N NBR Neoprene® Viton® consult factory for others
9	Shield <sup>(1)</sup>		None		ASTM D351 Mica Gr. V-4 PCTFE (replaces Kel-F®)
48	Glass		Reflex or transparent style tempered Borosilicate		Aluminosilicate (transparent only)
100	Cap screw or U-bolt		AISI 4140 or 4142 alloy steel per ASTM A193 Gr. B7		ASTM A193 Gr. B8M Cl. 2 316 STS ASTM A153 galvanized steel
125	Washer		ASTM B633 zinc plated carbon steel		18-8 STS (302-304 STS)
331	Band		Rubber		None

**NOTE**

- Under no circumstances should shields be used in reflex style gages, as they will keep the fluid from coming into contact with the reflective prisms, thereby prohibiting visibility of the liquid level in the gage.

# PENBERTHY MODELS RL AND TL DIRECT READING LIQUID LEVEL GAUGES ACCESSORIES

## Gaugecocks

Penberthy Series 100 through 700 offset and straight pattern gaugecocks isolate the gauge chamber from the liquid contents of the vessel. Gaugecocks can be factory assembled in a variety of configurations

SIDE CONNECTED GAGE W/GAGECOCKS

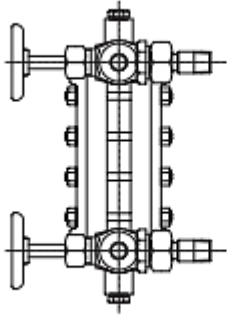
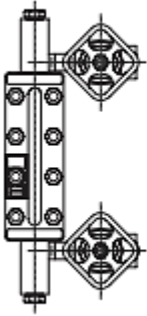

END CONNECTED GAGE W/GAGECOCKS

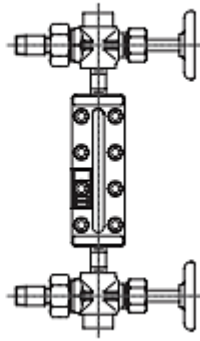

## Illuminators

Complementary illuminators are designed to improve liquid level observation by providing proper light distribution over the entire visible length of the transparent gauge when ambient light is insufficient. The illuminator is designed to be mounted readily on virtually any transparent gauge.

Continuous LED illuminators are available in sections up to 74" long. Multiple illumination sections can be stacked to accommodate virtually any visible length.

## Flexible fiberglass insulation blanket

Lightweight, silicone coated fiberglass cover and liner, with or without PTFE window. Can be used with frost proof extensions and illuminator

## External heating/cooling chamber

Double sided or single sided, does not contact liquid inside chamber

## Internal heating/cooling chamber

Heating/cooling tube passes through the inside of the gauge and is in direct contact with liquid

## Frost-proof extensions

Clear plastic windows that fit over the visible part of the glass in flat glass gauges. In low temperature applications, they inhibit build-up of frost over the visible part of the gauge, preventing obstruction of the liquid level view.

## Gauge scales

Attach to gauge cover to provide a graduated read out of liquid level. Available in a variety of units, feet/inch and meter/centimeter are standard

LED ILLUMINATOR

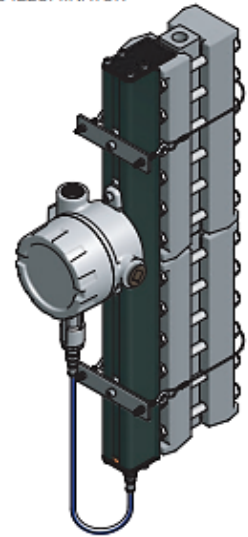

**PENBERTHY MODELS RL AND TL DIRECT READING LIQUID LEVEL GAUGES**  
**ORDERING INFORMATION - PART 1**

**SELECTION GUIDE**

<b>Example:</b>	<b>4</b>	<b>RL</b>	<b>7</b>	<b>C</b>	<b>G</b>	<b>C</b>	<b>X</b>
<b>No. of sections</b>							
<b>01</b>	1 Section						
<b>02</b>	2 Section						
<b>03</b>	3 Section						
<b>04</b>	4 Section						
<b>05</b>	5 Section						
<b>06</b>	6 Section						
<b>07</b>	7 Section						
<b>08</b>	8 Section						
<b>09</b>	9 Section						
<b>10</b>	10 Section						
<b>Gage type</b>							
<b>RL</b>	LP Reflex gage						
<b>TL</b>	LP Transparent gage						
<b>Glass size</b>							
<b>1</b>	Size 1						
<b>2</b>	Size 2						
<b>3</b>	Size 3						
<b>4</b>	Size 4						
<b>5</b>	Size 5						
<b>6</b>	Size 6						
<b>7</b>	Size 7						
<b>8</b>	Size 8						
<b>9</b>	Size 9						
<b>Wetted parts material (chamber)</b>							
<b>C</b>	Carbon steel (standard)						
<b>S</b>	316/316L Stainless steel						
<b>M</b>	Monel						
<b>A</b>	Alloy 20						
<b>H</b>	Hastelloy C						
<b>F</b>	304/304L Stainless steel						
<b>D</b>	Duplex 2205						
<b>Cover material</b>							
<b>G</b>	Ductile iron						
<b>Bolting material</b>							
<b>C</b>	STL A193 B7/A194 2H (standard)						
<b>S</b>	SST A193 B8M/A194 8M						
<b>N</b>	STL NACE A193 B7M/A194 2HM						
<b>E</b>	SST NACE A193 B8MA/A194 8MA						
<b>NACE MR-01-75 and/or MR-01-03</b>							
<b>X</b>	None						
<b>W</b>	NACE wetted						

**PART 2 - PAGE 10**

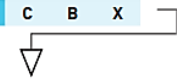

**PART 3 - PAGE 11**

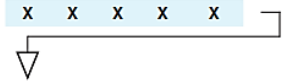

**PART 4 - PAGE 12**



**PENBERTHY MODELS RL AND TL DIRECT READING LIQUID LEVEL GAUGES**  
**ORDERING INFORMATION - PART 2**

**PART 1 - PAGE 9**

**SELECTION GUIDE - PART 2**

**PART 3 - PAGE 11**

4	RL	7	C	G	C	X	Example:	C	B	X	X	X	X	X	X	
							<b>End connection size</b>									
							<b>C</b> 1/2" (Standard)									
							<b>E</b> 3/4"									
							<b>F</b> 1" (flange only)									
							<b>G</b> 1 1/4" (flange only)									
							<b>H</b> 1 1/2" (flange only)									
							<b>J</b> 2" (flange only)									
							<b>End connection type</b>									
							<b>B</b> NPT female (standard)									
							<b>D</b> Socketweld female									
							<b>N</b> Raised face SO									
							<b>P</b> Flat face SO									
							<b>R</b> RTJ SO									
							<b>S</b> Raised face SW									
							<b>T</b> Flat face SW									
							<b>U</b> RTJ SW									
							<b>V</b> Raised face WN									
							<b>W</b> Flat face WN									
							<b>Y</b> RTJ WN									
							<b>F</b> Vent & drain plugged									
							<b>G</b> Drain plugged									
							<b>H</b> Vent plugged									
							<b>J</b> Socketweld male									
							<b>End connection pressure class</b>									
							<b>X</b> None									
							<b>1</b> 150#									
							<b>3</b> 300#									
							<b>6</b> 600#									
							<b>9</b> 900#									
							<b>F</b> 1500#									

**PART 4 - PAGE 12**

G	G	S	B	X	X	X	X
---	---	---	---	---	---	---	---



**PENBERTHY MODELS RL AND TL DIRECT READING LIQUID LEVEL GAUGES**  
**ORDERING INFORMATION - PART 3**

**PART 1 - PAGE 9**

4 RL 7 C G C X

**SELECTION GUIDE - PART 3**

**PART 4 - PAGE 12**

**PART 2 - PAGE 10**

C B X

Example:	X	X	X	X	X	G	G	S	B	X	X	X	X
<b>Side connection size</b>													
X None													
C ½" (standard)													
E ¾"													
F 1" (flange only)													
G 1¼" (flange only)													
H 1½" (flange only)													
J 2" (flange only)													
<b>Side connection type</b>													
X None													
B NPT female (standard)													
D Socketweld female													
M NPT male													
N Raised face SO													
P Flat face SO													
R RTJ SO													
S Raised face SW													
T Flat face SW													
U RTJ SW													
V Raised face WN													
W Flat face WN													
Y RTJ WN													
L Lap joint													
<b>Side connection pressure class</b>													
X None													
1 150#													
3 300#													
6 600#													
9 900#													
F 1500#													
<b>Side connection location</b>													
X None													
S Right side connected (standard)													
L Left side connected													
B Back connected													
F Front connected													
G One bottom right													
H One bottom left													
J One top right													
K One top left													
M One bottom back													
<b>Connection dimension</b>													
X None													
00000 Inches (first 3 digits = number of whole inches, last 2 digits = fraction of an inch in hundredths)													

**PENBERTHY MODELS RL AND TL DIRECT READING LIQUID LEVEL GAUGES**  
**ORDERING INFORMATION - PART 4**

**PART 1 - PAGE 9**

4 RL 7 C G C X

**SELECTION GUIDE - PART 4**

**Example:** G G S B X X X X

**PART 2 - PAGE 10**

C B X

**PART 3 - PAGE 11**

X X X X X

**Gasket material**

- G Grafoil/Mylar (Standard)
- S Grafoil/SS insert
- B Nobestos D7301
- T ePTFE (Gore GR)
- K Garlock 3300
- L Gylon 3510
- Y Gylon 3504
- A Garlock IFG-5500 (Standard)
- U Buna-N NBR
- V Viton®
- D 25% glass filled PTFE
- P PCTFE (KEL-F)
- C TopChem 2000

**Cushion material**

- G Grafoil/Mylar (Standard)
- S Grafoil/SS insert
- B Nobestos D7301
- T ePTFE (Gore Gr)
- K Garlock 3300
- L Gylon 3510
- Y Gylon 3504
- A Garlock IFG-5500 (standard)
- U Buna-N NBR
- V Viton®
- D 25% glass filled PTFE
- P PCTFE (KEL-F)
- C TopChem 2000

**Paint specification**

- X None
- S Standard
- O Offshore Paint

**Option 1**

- X None
- A 1 External htg/clg chbr.
- B 1 Welded support bracket
- C 2 Welded support brackets
- D 3 Welded support brackets
- K Belleville washers

**Option 2**

- X None

**Option 3**

- X None
- B Mica Shields V2/V4 (.005-.007" thick)
- C PCTFE shields (KEL-F)
- D Mica Shields V2/V4 (.009-.012" thick)

**Option 4**

- X None

**Option 5**

- X None

**Authorised Distributor:**



**NATIONWIDE OIL & GAS**  
 46, Jalan SS 22/21, Damansara Jaya,  
 47400 Petaling Jaya,  
 Selangor Darul Ehsan, Malaysia.  
 Email: [nog@nog.com.my](mailto:nog@nog.com.my)  
 Website: [www.nog.com.my](http://www.nog.com.my)

