

PENBERTHY SERIES ELL, HLM, SRH AND CTE2 FOR HEATING LIQUIDS

Practical, simple and cost-effective alternatives for heating liquids in-line or in an open tank



FEATURES

- Simple design with no moving parts to wear out.
- No packing glands.
- No lubrication required.
- Virtually maintenance-free.
- Easy to install without special structures or foundations.
- Cast or fabricated constructions.
- Variety of materials to suit specific characteristics of the process liquids.
- Critical flow paths machined smoothly with no abrupt turns or steps, producing the most efficient flow during the motive function.

GENERAL APPLICATION

Applications for inline heaters include: circulating cleaning solutions, pasteurization, producing scalding sprays, sterilization, heating water, blanching, exchanging heat, degreasing, heating slurries, laundering, cooking, pickling, bonderizing, quenching and tempering. For open tank heaters: cooking grain, mash or starch, heating and circulating, mixing.

TECHNICAL DATA

Materials:	Bronze, carbon steel, 316SS
Sizes:	¼" to 12"
Pressure (max):	150 psig (10.3 barg) 250 psig (17.2 barg)

PENBERTHY®

16633 Foltz Parkway, Strongsville, OH 44149 USA • Telephone: +440-572-1500
www.PenberthyProcess.com • sales@PenberthyProcess.com

PRODUCT OVERVIEW

Three series of Penberthy steam jet heaters are used for heating liquids in line. One models is available for heating liquids in tanks.

Models ELL, HLM and SRH in-line mixers can heat in-line while transporting the process media. Steam jet heaters optimize the condensation of steam into the motive medium to heat the fluid.

CTE2 circulating tank eductor heaters are open tank heaters that combine steam and liquid in vessels where contents may be recirculated.

OPERATION

Steam jet heaters optimize the condensing of steam into operating liquids to provide efficient fluid heating. They re essentially jet pumps and, as such, operate on the principle of one fluid entraining a second fluid.

Steam jet heaters have three common features (designations may vary according to design): inlet, suction and discharge.

Inlet – The operating liquid (sometimes called the motive) under pressure enters the inlet and travels through the nozzle into the suction chamber. The nozzle converts the pressure of the operating liquid stream emerging from the inlet nozzle, lowering the pressure in the suction chamber. The resulting action causes the steam in the suction chamber to flow toward the discharge.

Discharge (sometimes called outlet) – The entrained steam in the suction chamber mixes and condenses into the operating liquid and acquires part of its energy, flowing into the parallel section. In the diffuser section, part of the velocity of the mixture is converted into a pressure greater than the suction pressure, but lower than the inlet pressure.

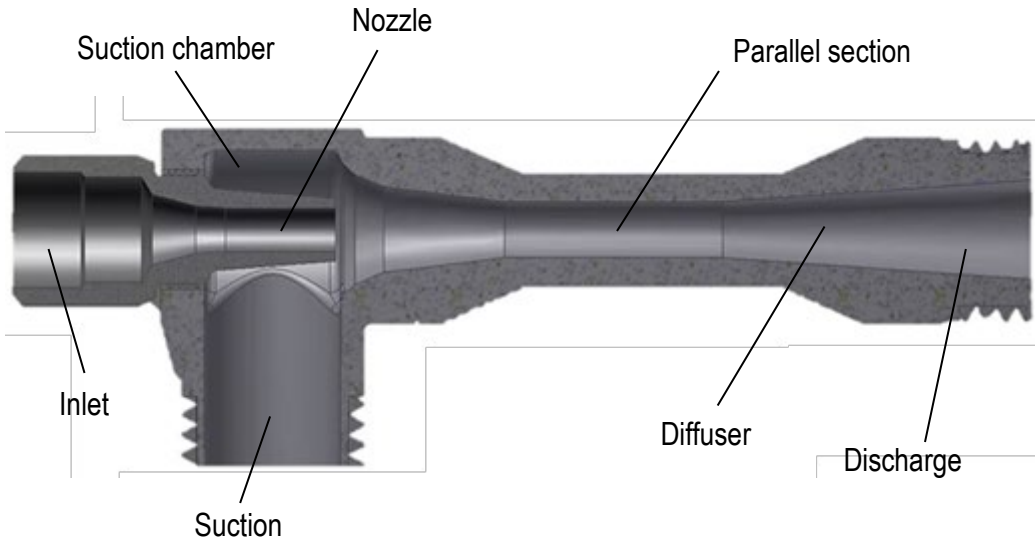

USING LIQUID AS THE OPERATING (inlet) MEDIUM, STEAM AS A SUCTION STREAM HEAT SOURCE

Models ELL, HLM and SRH are available for heating liquids in line. These models are ejector type heaters capable of operating at steam pressures lower than the operating liquid pressure. They offer much higher BTU input than a comparable steam ring heater, while incurring a higher inlet-to-discharge pressure drop.

ELL and HLM models are typically used as single pass devices. The SRH-steam ring heater is a low pressure drop inline heater for single pass or multi-pass applications.

These inline heaters provide heat and operating pressure for cleaning solution circulation, producing scalding sprays, heating water and slurries, exchanging heat and cooking. The table lists the operating parameters of each.

TABLE 1 - MODEL SPECIFICATIONS

Model	ELL Low steam pressure	HLM High steam pressure	SRH Steam ring heater
Steam pressure	up to 45 psig (310 kPag)	up to 120 psig** (830 kPag)	up to 150 psig (1035 kPag)
Max. water temp. rise (ΔT)*	up to 182°F (83°C)	up to 216°F (102°C)	up to 200°F (93°C)
Max. capacity	5000 gpm (18925 lpm)	5000 gpm (18925 lpm)	500 gpm (1893 lpm)

* Based on 60°F inlet water

** Max. steam pressure for iron body material, 60 psig

SELECTING THE APPROPRIATE HEATER

To choose the appropriate inline heater for the application, compare the available steam pressure to the line pressure of the liquid to be heated. If the steam pressure is lower than or equal to the liquid pressure, an ELL or HLM heater must be used. If the steam pressure is higher than the liquid pressure, the ELL, HLM or SRH can be used. In this latter case, the ELL and HLM offer higher steam flows than the SRH (see Table 1). In on/off heating applications or during periods when steam input is halted, the ELL and HLM produce very large pressure drops. The SRH maintains its low pressure drop characteristics even when steam input is removed.

When using the HLM or ELL heater and when the discharge pressure exceeds one third of the operating pressure, the heater discharge pressure should be lowered during start-up, until the heater is operating, i.e. until both steam and water flows are established.

ELL, HLM MODELS

Each of the two models is available in 15 sizes from ½” to 12” suction and discharge. Units are cast construction in ½” through 4” sizes. Sizes 4” through 12” are available in fabricated construction.

Cast unit connections

Units ½” through 3” in size have NPT inlet, suction and discharge connections. 4” size has NPT inlet and flanged suction and discharge. Flanges on cast units are raised faced with holes, sizes and spacing corresponding to 150 lb ASME flanges.

Fabricated unit connections

All fabricated ELL and HLM units, 4” through 12” sizes, have raised faced flanges with holes, sizes and spacing corresponding to 150 lb ASME flanges.

NOTE

Always specify material, model and unit size when ordering.

TABLE 2 - MODEL CONSTRUCTION DATA

Model	ELL, HLM	Standard materials
Sizes available	½”A - 4”	Cast: bronze, C. steel, 316 STS
	4” and up	Fabricated: Carbon steel, 316 STS

The ELL and HLM heaters operate with direct connections from steam and liquid lines. Though application and performance characteristics vary between the two, steam consumption is equal for a given temperature rise. As a general rule, steam flow is calculated as follows:

$$Q_s = \frac{Q_m \Delta T}{120}$$

Where:

Q_s = steam flow in lbs/min

Q_m = operating liquid in gpm

ΔT = temperature rise in °F

The following general operating characteristics will help in selecting the correct model heater:

ELL operates generally low to medium suction steam pressure (from 25” Hg vacuum to 45 psig). Performance capabilities include up to 182 °F temperature rise and up to 94 psig discharge pressure.

HLM operates over the widest range of performance characteristics and is usually the choice for most heating applications. It operates in a high steam pressure range (up to 120 psig), produces a high temperature rise (up to 216 °F) at a high discharge pressure (up to 184 psig).

Heater selection using performance charts

The following information is required to select the correct model:

- Operating liquid (for liquids other than water, consult the factory)
- Operating liquid inlet pressure, psig (h_m)
- Desired operating liquid capacity, gpm (Q_m)
- Operating liquid inlet temperature, °F (contact the factory when operating liquid inlet temperature exceeds 100°F)
- Desired temperature rise, °F (ΔT)
- Available steam pressure, psig (h_s)
- Minimum discharge pressure required, psig (h_d)
- Quality of steam available, i.e. saturated or superheated

PENBERTHY SERIES ELL, HLM, SRH AND CTE2 FOR HEATING LIQUIDS

HEATING LIQUIDS IN LINE

ELL, HLM MODELS

Evaluating both the ELL and HLM is recommended before choosing the model that best fits the operating conditions, by using the following procedure:

Step 1 – Refer to the heater performance chart for the selected model.

Locate the operating liquid (water) pressure psig (h_m) for your application.

Step 2 – In this (h_m) row, read across to find the desired temp. rise °F and note the steam pressure (h_s), disch. press. psig (h_d) and liquid flow (Q_m).

Step 3 – The performance charts indicate the capacities of 1 ½" units. To select units closest to actual requirements (one that equals or exceeds the required low) it may be necessary to calculate several sizes other than 1 ½" (refer to the example).

Example

To heat operating liquid 100 gpm water (Q_m) from 60 to 185° (ΔT 125°F)

Operating liquid, psig (h_m):	40
Available steam pressure (h_s):	150
Minimum discharge pressure required (h_d):	25

From the HLM performance chart:

Opposite 40 psig operating liquid inlet pressure (h_m) locate desired temperature rise (ΔT) 125 °F (between 121 and 132). The required steam pressure (h_s) will be between 40 and 45 psig. The discharge pressure (h_d) is greater than the minimum pressure required. The liquid flow (Q_m) is 23 gpm which is below the requirement of 100 gpm.

To select a larger unit for the 100 gpm requirement, try the next available sizes – the 2", 2 ½", and 3" units using the capacity factors in the chart.

2" size CF = 1.82

Heating capacity = $23 \times 1.82 = 41$ gpm (too low)

2 ½" size CF = 3.17

Heating capacity = $23 \times 3.17 = 73$ gpm (too low)

3" size CF = 5.92

Heating capacity = $23 \times 5.92 = 136$ gpm (exceeds requirements)

Repeat this procedure for the ELL

In this example, the ELL-3 comes closest to fitting the requirements. However, the steam pressure supplied to the ELL-3 would have to be throttled down from 150 psig to only 8 psig. This degree of throttling may be impractical, so the HLM-3 would be the more appropriate choice.

PENBERTHY SERIES ELL, HLM, SRH AND CTE2 FOR HEATING LIQUIDS
HEATING LIQUIDS IN LINE

ELL, HLM MODELS - PERFORMANCE

TABLE 3 - 1½ MODEL ELL HEATER PERFORMANCE CHART (water)

Operating water, psig (h _m)	Data description	Steam pressure (h _s)																										
		Inches Hg. vacuum					Pounds per square inch gauge																					
		25"	20"	15"	10"	5"	0	2	4	5	6	8	10	12	14	15	16	18	20	22	24	25	26	28	30	35	40	45
20	*	-	-	40	60	77	100	115	126	133	140	150	-	-	-	-	-	-	-	-	-	-	-	-	-	-	-	-
	**	-	-	0	0	8	10	12	14	14	14	14	-	-	-	-	-	-	-	-	-	-	-	-	-	-	-	-
	***	-	-	10	10	10	15	15	15	14	14	14	-	-	-	-	-	-	-	-	-	-	-	-	-	-	-	-
30	*	9	24	36	56	69	86	100	113	118	123	136	144	154	-	-	-	-	-	-	-	-	-	-	-	-	-	-
	**	0	5	8	15	18	19	20	21	21	21	21	21	21	-	-	-	-	-	-	-	-	-	-	-	-	-	-
	***	21	21	21	21	20	20	19	18	18	18	17	17	15	-	-	-	-	-	-	-	-	-	-	-	-	-	-
40	*	11	25	36	52	85	80	90	99	105	111	128	132	143	153	-	-	-	-	-	-	-	-	-	-	-	-	-
	**	5	6	13	18	22	25	26	27	28	29	29	30	30	30	-	-	-	-	-	-	-	-	-	-	-	-	-
	***	23	23	23	23	22	22	22	22	21	21	20	20	19	19	-	-	-	-	-	-	-	-	-	-	-	-	-
50	*	14	22	36	48	60	79	83	92	96	100	111	122	130	139	145	150	-	-	-	-	-	-	-	-	-	-	
	**	8	10	11	19	24	27	30	31	32	34	35	36	36	37	37	37	-	-	-	-	-	-	-	-	-	-	
	***	25	25	25	25	25	25	24	24	24	23	23	22	22	21	21	-	-	-	-	-	-	-	-	-	-	-	-
60	*	14	22	31	43	57	71	76	84	89	94	104	112	120	126	131	134	147	-	-	-	-	-	-	-	-	-	-
	**	12	14	16	24	28	29	32	33	34	36	39	41	42	43	43	41	41	-	-	-	-	-	-	-	-	-	-
	***	27	27	27	27	27	27	26	26	26	26	25	25	24	24	24	23	23	-	-	-	-	-	-	-	-	-	-
70	*	14	34	36	47	56	64	73	78	83	88	96	105	112	122	125	128	140	148	-	-	-	-	-	-	-	-	-
	**	13.5	16	18	28	30	35	38	38	38	39	42	44	44	44	44	44	44	-	-	-	-	-	-	-	-	-	-
	***	29	29	29	29	29	29	29	20	20	20	27	27	27	27	26	26	26	-	-	-	-	-	-	-	-	-	-
80	*	10	20	32	44	54	82	88	78	80	82	90	97	104	112	115	118	127	144	150	-	-	-	-	-	-	-	-
	**	17	18	21	26	32	37	38	40	42	44	45	46	49	48	48	48	48	48	48	-	-	-	-	-	-	-	-
	***	31	31	31	31	31	31	31	31	31	30	30	29	29	29	28	28	28	28	28	-	-	-	-	-	-	-	-
90	*	10	22	30	42	50	64	65	72	76	80	88	92	100	108	111	113	120	128	138	141	-	-	-	-	-	-	-
	**	20	22	23	27	35	39	42	44	45	48	58	52	53	56	56	57	59	59	59	59	-	-	-	-	-	-	-
	***	32	32	32	32	32	32	32	32	32	32	32	32	31	31	31	31	30	29	29	-	-	-	-	-	-	-	-
100	*	7	17	26	40	48	68	70	72	74	80	86	92	95	99	102	108	114	120	127	134	140	144	149	154	172	182	
	**	23	24	26	29	35	42	44	46	48	51	54	56	57	58	59	60	63	65	67	69	70	71	72	73	76	76	
	***	33	33	33	33	33	33	33	32	32	32	32	32	32	32	32	31	31	31	31	30	30	30	30	30	30	30	
120	*	7	10	20	37	44	59	63	67	69	73	76	82	88	92	97	101	106	111	116	121	125	127	132	137	155	169	180
	**	28	30	32	34	37	48	51	53	54	56	59	61	64	67	68	69	71	73	76	78	80	81	82	83	86	90	90
	***	36	36	36	36	36	36	36	36	36	36	36	35	35	35	35	35	34	34	34	33	33	33	32	32	32	32	32
140	*	6	14	24	34	43	54	58	61	63	67	74	80	84	88	91	94	98	104	108	112	114	118	124	130	140	156	168
	**	34	38	38	41	43	50	54	58	60	62	68	69	72	74	75	76	78	80	83	85	88	88	91	94	94	94	94
	***	39	39	39	39	39	39	39	39	39	39	38	38	38	38	38	38	38	38	37	37	37	37	37	37	37	37	37

* Temp rise - °F (ΔT)
 ** Disch press - psig (h_d)
 *** Liquid flow - gpm (Q_m)

NOTE
 All data based on 32°-100°F operating liquid temperatures. For other temperatures, consult factory.

CAUTION
 Attempted operation within the areas to the right of the figures will cause uncondensed steam to discharge from the heater.



PENBERTHY SERIES ELL, HLM, SRH AND CTE2 FOR HEATING LIQUIDS
HEATING LIQUIDS IN LINE

ELL, HLM MODELS - PERFORMANCE

TABLE 4 - 1½ MODEL HLM HEATER PERFORMANCE CHART (water)

Operating water, psig (hm)	Data description	Steam pressure (h _g)																					
		Inches Hg. Vacuum					Pounds per square inch gauge																
		25"	20"	15"	10"	5"	5	10	15	20	25	30	35	40	45	50	60	70	80	90	100	110	120
10	*	-	-	24	32	40	55	64	106	127	144	166	-	-	-	-	-	-	-	-	-	-	-
	**	-	-	4	4	6	17	20	24.5	30.5	34	30	-	-	-	-	-	-	-	-	-	-	-
	***	-	-	17	17	16	16	15	15	14	14	12	-	-	-	-	-	-	-	-	-	-	-
20	*	-	15	20	25	34	61	64	80	88	107	120	134	152	-	-	-	-	-	-	-	-	-
	**	-	4	7	10	15	20	25	30	35	30	42	46	51	-	-	-	-	-	-	-	-	-
	***	-	20	20	20	20	20	19	19	18	18	18	17	16	-	-	-	-	-	-	-	-	-
30	*	1	12	18	23	30	55	58	65	77	90	103	114	128	140	153	185	-	-	-	-	-	-
	**	5	7	8.5	11	15	22	27	33	37	41	45	52	55	60	65	75	-	-	-	-	-	-
	***	23	23	23	23	22	23	23	22	22	22	22	22	20	20	19	18	-	-	-	-	-	-
40	*	4	10	14	20	27	42	54	57	67	81	91	102	121	132	144	170	190	-	-	-	-	-
	**	8	11	14	17	20	25	28	32	37	42	48	53	57	62	68	77	80	-	-	-	-	-
	***	25	25	25	25	25	25	25	25	24	24	24	23	23	23	22	21	21	-	-	-	-	-
50	*	3	6	14	19	22	36	47	57	68	80	90	102	112	122	132	161	180	200	-	-	-	-
	**	12	15	17	21	23.5	30	35	40	45	50	55	64	68	70	75	85	96	101	-	-	-	-
	***	28	28	28	28	28	27	27	27	26	26	26	26	25	25	24	23	23	22	-	-	-	-
60	*	2	8	12	18	22	34	44	54	64	73	82	92	100	110	120	142	162	184	204	-	-	-
	**	14	19	21	24	27	35	36	44	50	55	61	66	71	75	80	83	101	104	105	-	-	-
	***	30	30	30	30	30	30	30	29	29	29	28	28	28	27	27	25	25	24	24	-	-	-
70	*	3	7	12	17	21	33	42	51	60	69	78	85	94	103	112	130	148	168	188	200	-	-
	**	18	21	25	28	31	38	43	48	53	58	65	69	73	79	85	92	104	103	122	133	-	-
	***	32	32	32	32	32	32	32	31	31	31	31	30	30	30	30	29	28	27	26	26	-	-
80	*	4	8	12	15	20	32	40	46	55	64	71	80	90	95	105	115	142	154	165	174	212	-
	**	22	26	29.5	31	34	42	48	52	57	62	65	72	72	79	86	91	107	113	128	138	142	-
	***	33	33	33	33	33	33	33	33	33	32	32	32	32	31	31	31	30	30	29	28	27	-
90	*	3	8	11	15	20	30	37	44	51	60	69	76	86	91	97	116	132	146	160	175	196	215
	**	27	29	33	36	38	43	51	55	61	66	72	76	81	85	90	101	112	120	131	140	144	163
	***	35	35	35	35	35	35	35	35	34	34	34	34	34	34	33	33	32	32	31	31	29	29
100	*	2	6	10	14	19	30	38	41	50	56	62	70	80	87	94	108	123	140	150	164	184	196
	**	28	30	32.5	38	41	45	54	59	64	69	73	78	84	89	95	104	114	126	132	142	154	155
	***	36	36	36	36	36	36	36	36	36	36	36	36	36	36	35	35	34	34	33	33	33	32
120	*	2	6	10	13	17	28	30	39	45	52	59	65	72	79	88	98	115	128	145	155	168	189
	**	30	37	40	45	49	58	61	66	71	78	80	88	91	96	100	112	123	132	145	150	161	174
	***	40	40	40	40	40	40	40	40	40	40	39	39	39	39	38	37	37	37	36	36	35	35
140	*	2	5	10	12	15	27	30	36	44	49	55	61	66	71	77	90	103	116	125	144	158	170
	**	38	47	50	53	58	64	67	72	82	83	88	96	97	102	108	120	130	139	148	162	172	184
	***	43	43	43	43	43	43	43	42	42	42	42	42	42	42	42	42	42	40	40	40	40	39

* Temp rise - °F (ΔT)

** Disch press - psig (h_g)

*** Liquid flow - gpm (Q_m)

NOTE

All data based on 32°-100°F operating liquid temperatures. For other temperatures, consult factory.

CAUTION

Attempted operation within the areas to the right of the figures will cause uncondensed steam to discharge from the heater.

TABLE 5 - ELL, HLM CAPACITY FACTOR

½A	½B	½	¾	1	1¼	1½	2	2½	3	4	6	8	10	12
0.03	0.047	0.121	0.208	0.344	0.613	1	1.82	3.17	5.92	11.8	24	49	71	123



PENBERTHY SERIES ELL, HLM, SRH AND CTE2 FOR HEATING LIQUIDS
HEATING LIQUIDS IN LINE

ELL, HLM MODELS - PERFORMANCE

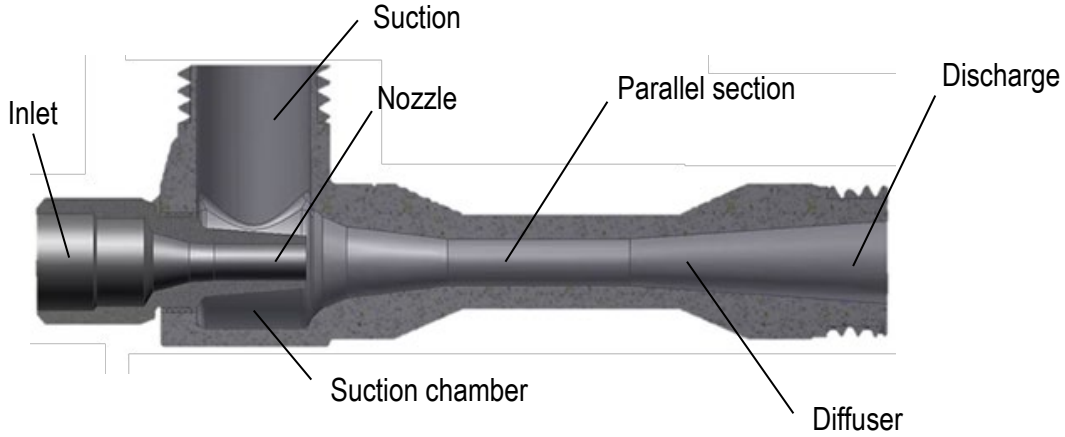

TABLE 6 - CAST ELL, HLM DIMENSIONS (in inches)

Size	A	B	C	D	E*	F*
1/2 A	4 3/8	1 1/2	1 1/4	1/4	1/2	1/2
1/2 B	4 3/8	1 1/2	1 1/4	1/4	1/2	1/2
1/2	4 1/2	1 5/8	1 1/4	3/8	1/2	1/2
3/4	5 7/8	2	1 1/2	1/2	3/4	3/4
1	7 1/8	2 1/4	1 3/4	3/4	1	1
1 1/4	9	2 1/2	2 1/4	1	1 1/4	1 1/4
1 1/2	11	2 3/4	2 1/2	1	1 1/2	1 1/2
2	14 3/8	3 3/8	3	1 1/4	2	2
2 1/2	18 1/4	3 1/2	4 1/8	1 1/2	2 1/2	2 1/2
3	23 3/4	4	5	2	3	3
4	32 1/2	5	6	3	4❖	4❖

* All cast units have NPT connections except: 4" size has NPT inlet, flanged suction and discharge
❖ flange

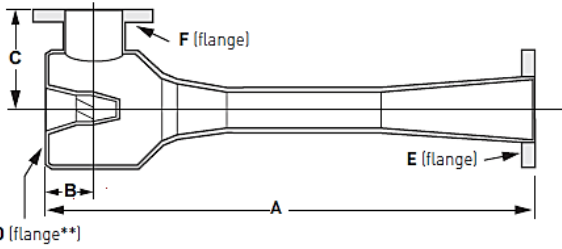

TABLE 7 - FABRICATED ELL DIMENSIONS (in inches)

Size	A	B	C	D**	E	F
4	38 1/4	5 1/4	8	3	4	4
6	52 7/8	5 7/8	9 1/2	4	6	6
8	74 7/16	8 7/16	13	6	8	8
10	87 3/8	10 3/8	14	8	10	10
12	110 3/4	11 3/4	18	10	12	12

** Inlet flanges on fabricated units have blind tapped holes.

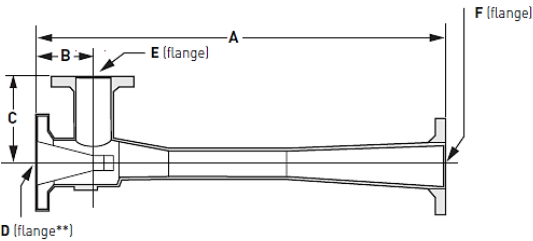

TABLE 8 - FABRICATED HLM DIMENSIONS (in inches)

Size	A	B	C	D	E	F
4	38 1/4	5 1/4	8	4	3	4
6	52 7/8	5 7/8	9 1/2	6	4	6
8	74 7/16	8 7/16	13	8	6	8
10	87 3/8	10 3/8	14	10	8	10
12	110 3/4	11 3/4	18	12	10	12

PENBERTHY SERIES ELL, HLM, SRH AND CTE2 FOR HEATING LIQUIDS
HEATING LIQUIDS IN LINE

MODEL SRH

SRH (Steam Ring Heaters) are compact, inline units with low pressure drop. SRH units inject steam through a ring-shaped opening within an enlargement in the pipeline. Liquid passes through and around the ring. Heat is introduced by the direct condensation of steam. They provide fast temperature correction noiselessly and without vibration if applied correctly. Because the liquid flow area is unrestricted, pressure drops across the heater are minimized. This will reduce the horsepower requirements for the operating liquid pump.

Model SRH is available in inlet and outlet sizes of 1 1/2", 2" and 3" threaded and 6" flanged.

NOTE

Always specify material, model and unit size when ordering.

TABLE 9 - MODEL CONSTRUCTION DATA

Model	SRH	Standard materials
Sizes available	1 1/2", 2", 3", 6"	Bronze, carbon steel, 316 STS

The following information is required to select the correct model:

Operating liquid (for liquids other than water, consult the factory)

- Operating liquid inlet pressure, psig (h_m)
- Desired operating liquid capacity, gpm (Q_m)
- Operating liquid inlet temperature, °F (contact the factory when operating liquid inlet temperature exceeds 100°F)
- Desired temperature rise, °F (ΔT)
- Available steam pressure, psig (h_s)
- Minimum discharge pressure required, psig (h_d)
- Quality of steam available (i.e. saturated or superheated)
- Maximum pressure drop (ΔP). Refer to Tables 11, 12 and 13

DIMENSIONS

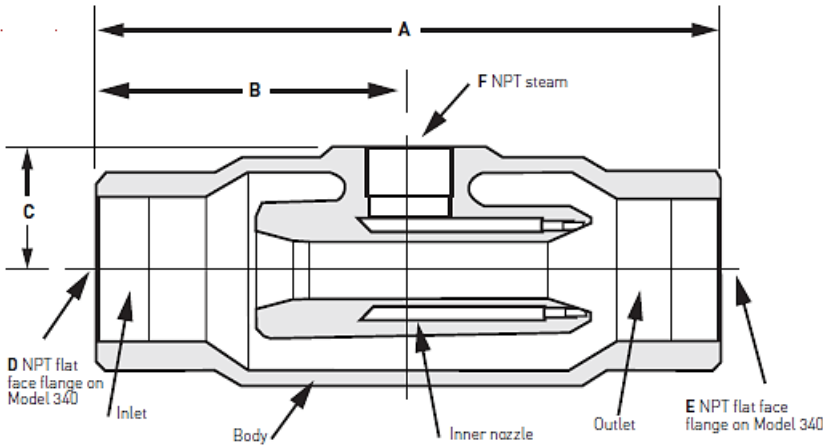

TABLE 10 - SRH DIMENSIONS (in inches)

Unit	Inlet	Outlet	Steam	A	B	C
310	1 1/2	1 1/2	1	6 5/8	3 3/8	1 3/4
320	2	2	1 1/4	9 3/4	4 7/8	1 7/8
330	3	3	1 3/4	10 3/4	5 3/8	2 1/2
340	6(*)	6(*)	2	10	5	3 3/4

* Flanged.

MODEL SRH

The following steps are provided for selecting the correct size SRH:

- Step 1 – In the steam consumption chart (Table 13) locate the point where the desired water flow gpm and temperature rise in °F (ΔT) intersect. Read off the steam consumption in lbs/min.
- Step 2 – In the SRH performance chart (Table 12), locate the point where the operating water press. psig (h_m) and steam pressures (h_s) intersect. These represent the various steam consumptions for individual SRH units. Those with consumptions from the chart in Step 1 indicate the SRH model to choose.
- Step 3 – If the steam flow shown for the model selected is greater than required, throttle the steam to a pressure that will provide the required steam flow.

To determine the pressure drop for the selected unit use the formula as shown.

The rational flow formula is:

$$dp = \left[\frac{GPM}{C_v} \right]^2 G$$

or

$$GPM = C_v \sqrt{dp/G}$$

GPM – U.S. gallons per minute

C_v – Unit flow coefficient

G – Specific gravity

dp – Pressure drop across the unit, psid

C_v is defined as the number of U.S. gallons of water per minute that will flow through the unit at a 1 psi pressure drop.

Example:

To find the pressure drop for a 320 heater with a flow of 150 gpm:

$$dp = \left[\frac{GPM}{C_v} \right]^2 G$$

$$dp = \left[\frac{150}{75} \right]^2 (1)$$

$$dp = 4 \text{ psid}$$

Example

To heat 150 gpm water from 70 to 85 °F (ΔT 15 °F)

Operating liquid inlet pressure, psig (h_m): 40

Available steam pressure, psig (h_s): 80

Maximum pressure drop, psig (ΔP): 5

From Step 1 of the procedure, the steam consumption is 18.7 lb/min.

From Step 2 note the steam consumption closest to 18.7. Model 310 will handle 18 lb/min, just below our requirement and model 320 will handle 27 lb/min.

From Step 3, select the model with the higher available steam consumption and throttle the steam accordingly. The performance chart (Table 12) indicates that the model 320 should be throttled to slightly above 60 psig to achieve the desired consumption of 18.7 lbs/min.

Note that the maximum allowable pressure drop (ΔP) is 5 psig in this example. Using the rational flow formula example for the model 320 selected, we see the pressure drop is 4 psig below the stated maximum.

PENBERTHY SERIES ELL, HLM, SRH AND CTE2 FOR HEATING LIQUIDS
HEATING LIQUIDS IN LINE

MODEL SRH - PERFORMANCE

TABLE 11 - SRH SIZING COEFFICIENT

Unit	C _v liquid sizing coefficient (gpm)	Heat input max. (BTU Min. at 150 psig wsp)*
310	50	32000
320	75	48000
330	125	79000
340	350	128000

* Working steam pressure (at operating liquid pressure of 80 psig)

TABLE 12 - SRH PERFORMANCE - STEAM CONSUMPTION IN lbs/min (Q_s)

Op. water press.**, psig (h _m)	Model	Steam pressure, psig (h _s)											
		20	30	40	50	60	70	80	90	100	120	140	150
10	310	6	9	11	13	15	17	19	21	23	26	30	32
	320	9	14	17	20	22	25	28	31	34	40	45	48
	330	16	23	28	33	37	42	47	52	56	66	75	79
	340	25	36	45	52	60	68	75	83	90	106	121	128
20	310	-	7	10	13	15	17	18	21	23	26	30	32
	320	-	10	15	19	22	25	28	31	34	40	45	47
	330	-	17	25	31	37	42	47	52	56	66	75	79
	340	-	28	40	50	59	68	75	83	90	106	121	127
40	310	-	-	-	9	12	15	18	20	23	26	30	32
	320	-	-	-	13	18	23	27	31	34	40	45	47
	330	-	-	-	22	31	38	45	51	56	66	75	79
	340	-	-	-	35	49	61	72	82	90	106	121	127
60	310	-	-	-	-	-	11	15	19	21	26	30	32
	320	-	-	-	-	-	16	22	28	32	39	45	47
	330	-	-	-	-	-	26	37	46	53	65	75	79
	340	-	-	-	-	-	42	60	74	86	104	120	126
80	310	-	-	-	-	-	-	-	13	18	25	30	32
	320	-	-	-	-	-	-	-	20	27	37	44	47
	330	-	-	-	-	-	-	-	32	44	61	74	78
	340	-	-	-	-	-	-	-	52	71	98	119	126

All data based on 32° to 100°F inlet water temperature (T_m). For other inlet water temperatures consult the factory.

**[with water flowing]

NOTE

Operation shown in bold is susceptible to high frequency noise.

PENBERTHY SERIES ELL, HLM, SRH AND CTE2 FOR HEATING LIQUIDS
HEATING LIQUIDS IN LINE

MODEL SRH - PERFORMANCE

TABLE 13 - SRH STEAM CONSUMPTION (lbs per minute) RELATED TO TEMPERATURE RISE AND WATER FLOW*

Water flow, gpm (Q _m)	Temperature rise in °F (ΔT)														
	5	10	15	20	25	30	35	40	45	50	55	60	65	70	75
10	0.4	0.8	1.2	1.7	2.1	2.5	2.9	3.3	3.7	4.2	4.6	5.0	5.4	5.8	6.2
15	0.6	1.2	1.9	2.5	3.1	3.7	4.4	5.0	5.6	6.2	6.9	7.5	8.1	8.7	9.4
20	0.8	1.7	2.5	3.3	4.2	5.0	5.8	6.7	7.5	8.3	9.2	10.0	10.8	11.7	12.5
25	1.0	2.1	3.1	4.2	5.2	6.2	7.3	8.3	9.4	10.4	11.4	12.5	13.5	14.5	15.7
35	1.6	2.9	4.4	5.8	7.3	8.7	10.2	11.7	13.1	14.6	16.0	17.6	18.8	20.0	22.0
45	1.9	3.7	5.2	7.5	9.4	11.2	13.1	15.0	16.9	18.7	21.0	22.0	24.0	28.0	28.0
50	2.5	5.0	7.5	10.3	12.5	15.0	17.5	20.0	22.0	25.0	27.0	30.0	32.0	35.0	37.0
60	3.3	6.7	10.0	13.3	16.7	20.0	23.0	27.0	30.0	33.0	37.0	40.0	43.0	47.0	50.0
100	4.2	8.3	12.5	16.7	21.0	25.0	29.0	33.0	37.0	42.0	46.0	50.0	54.0	58.0	62.0
125	5.2	10.4	15.8	21.0	27.0	31.0	38.0	42.0	47.0	52.0	57.0	62.0	68.0	73.0	78.0
150	6.2	12.5	18.7	25.0	31.0	37.0	44.0	50.0	55.0	62.0	69.0	75.0	81.0	87.0	94.0
175	7.3	14.6	22.0	29.0	36.0	44.0	51.0	58.0	66.0	73.0	80.0	87.0	95.0	102.0	109.0
200	8.3	16.7	25.0	33.0	42.0	50.0	58.0	67.0	75.0	83.0	92.0	100.0	108.0	117.0	125.0
250	10.4	21.0	31.0	42.0	52.0	62.0	73.0	83.0	94.0	100.0	114.0	125.0	135.0	148.0	158.0
300	12.5	25.0	39.4	50.0	62.0	74.0	85.0	100.0	112.0	124.0	136.0	150.0	162.0	175.0	187.0
400	17.0	33.0	50.0	67.0	83.0	100.0	117.0	133.0	150.0	167.0	183.0	200.0	217.0	233.0	250.0
500	21.0	42.0	62.0	83.0	104.0	125.0	146.0	166.0	187.0	200.0	229.0	250.0	271.0	291.0	312.0

TABLE 13 - SRH STEAM CONSUMPTION (lbs per minute) RELATED TO TEMPERATURE RISE AND WATER FLOW* (continued)

Water flow, gpm (Q _m)	Temperature rise in °F (ΔT)														
	80	85	90	95	100	110	120	130	140	150	160	170	180	190	200
10	6.7	7.1	7.5	7.9	8.3	9.2	10	10.8	11.7	12.5	13.3	14.2	15	15.8	16.7
15	10.0	10.6	11.2	11.9	12.5	13.7	15	16.2	17.5	18.7	20.0	21.0	22	24.0	25.0
20	13.3	14.2	15.0	15.8	16.7	18.3	20	22.0	23.0	25.0	27.0	28.0	30	32.0	33.0
25	15.7	17.7	18.7	19.8	21.0	23.0	25	27.0	29.0	31.0	33.0	35.0	37	40.0	42.0
35	23.0	25.0	26.0	28.0	29.0	32.0	36	38.0	41.0	44.0	47.0	50.0	52	55.0	58.0
45	30.0	32.0	34.0	36.0	37.0	41.0	45	49.0	52.0	58.0	60.0	64.0	67	71.0	75.0
50	40.0	42.0	45.0	47.0	50.0	55.0	60	65.0	70.0	75.0	80.0	85.0	90	95.0	100.0
60	53.0	57.0	60.0	63.0	67.0	73.0	80	87.0	93.0	100.0	107.0	113.0	120	127.0	133.0
100	67.0	71.0	75.0	79.0	83.0	92.0	100	108.0	117.0	125.0	133.0	142.0	150	158.0	167.0
125	83.0	88.0	94.0	99.0	104.0	115.0	125	135.0	148.0	158.0	167.0	177.0	187	198.0	208.0
150	100.0	105.0	112.0	119.0	125.0	137.0	150	162.0	175.0	187.0	200.0	212.0	225	237.0	250.0
175	117.0	124.0	131.0	136.0	146.0	160.0	175	189.0	204.0	219.0	233.0	243.0	262	277.0	291.0
200	133.0	142.0	150.0	158.0	167.0	183.0	200	217.0	233.0	250.0	267.0	283.0	300	317.0	333.0
250	167.0	177.0	187.0	198.0	208.0	229.0	250	271.0	291.0	312.0	333.0	354.0	375	396.0	416.0
300	200.0	212.0	225.0	237.0	250.0	275.0	300	325.0	350.0	375.0	400.0	425.0	450	475.0	500.0
400	267.0	283.0	300.0	317.0	333.0	367.0	400	433.0	466.0	500.0	533.0	566.0	600	633.0	666.0
500	333.0	354.0	375.0	396.0	416.0	458.0	500	541.0	583.0	625.0	666.0	708.0	750	791.0	833.0

* Based on 60°F inlet water



PENBERTHY SERIES ELL, HLM, SRH AND CTE2 FOR HEATING LIQUIDS
HEATING LIQUIDS IN LINE

CTE2 circulating tank eductor heaters are open tank heaters that combine steam and liquid in vessels where contents may be recirculated.

Open tank heaters provide circulation and efficient steam-liquid contact superior to coil heating without the noise of direct application. They are installed submerged in the tank.

Using up to 140 psig steam, Penberthy open tank heaters produce maximum temperature rises up to 120°F, depending on the size of the unit.

NOTE

Because of the nature of open tank installations, do not attempt to heat beyond the maximum stated temperature.

The submerged open tank heaters combine steam and liquid or slurry to recirculate the contents of a tank. They are especially suited for cooking, heating and circulating liquids.

Model CTE2 is a versatile heater that can also produce a strong mixing action throughout the tank contents. The CTE2 requires a minimum of 10 psig steam pressure.

TABLE 14 - MODEL SPECIFICATIONS

Model	CTE - Circulating Tank Eductor
Motive steam pressure	up to 140 psig (966 kPag)
Max. water temp. rise (ΔT)	up to 120°F (49° C)
Max. final tank temp.	up to 160°F (71° C)

MODELS CTE2

Model CTE2

The CTE2 (Circulating Tank Eductor) is an ejector-type jet, requiring no nipple, recommended for tanks in multiple installations near and parallel to the tank bottom. Steam inlet sizes range from 3/8" to 3".

TABLE 15 - MODEL CONSTRUCTION DATA

Model	CTE	Standard materials
Sizes available	3/8"-4" 4" and up	Cast: bronze, carbon steel, 316 STS Fabricated: Carbon steel, 316 STS

Unit selections using performance charts

The following information is required to select and size tank heaters:

- Tank liquid (if other than water, consult factory)
- Available steam pressure, psig (h_m)
- Desired temperature rise, °F (ΔT)
- Tank capacity, gallons
- Heating time, minutes
- Initial temperature of liquid °F (T_s)

NOTE

Always specify material, model and unit size when ordering.

MODEL CTE2

There are two methods provided here for selecting the correct unit.

Method 1 uses the steam consumption table (lb/min of steam).

Method 2 uses the performance table (heating capacity in gphm-gallons heated per minute).

Method 1

Step 1 – Multiply the total batch gallons by 8.33 lbs to find the weight (if water).

Step 2 – Multiply the result by the number of degrees temperature rise desired and divide this number by 1000 to determine the weight of steam (lbs) to do the job.

Step 3 – Divide this figure by the heating time required (in min.). This figure represents the rate of steam flow in pounds per minute.

Step 4 – Under available steam pressure, locate steam consumption equal to or greater than the requirement. At this point, move to the left and determine the unit size.

Method 1 example

This method can be used in the CTE2 heaters for water.

Operating conditions

Available steam pressure psig (h_m):	40
Desired temperature rise °F (ΔT):	40
Tank capacity, gallons:	800
Heating time, minutes:	60
Initial temperature of liquid °F (T_s):	40

Step 1 - $800 \text{ (gallons)} \times 8.33 \text{ (lbs)} = 6670 \text{ lbs, the weight of water}$

Step 2 - $\frac{6670 \times 40(\Delta T)}{1000} = 267 \text{ lbs, the weight of steam}$

Step 3 - $\frac{267 \text{ lbs}}{60 \text{ min}} = 4.45 \frac{\text{lb}}{\text{min}}$ required

Step 4 – from steam consumption chart – The CTE2 ¼ unit will handle 6 lbs/min, the steam may be throttled back to reduce the rate of steam consumption to the desired 4.45 lb/min.

NOTE

Multiple units can be used if desired. Select smaller units with total steam consumption equal to or greater than the desired flow rate obtained in Step 3.

MODELS CTE2

Method 2

The method can also be used in selecting the CTE2 heaters.

Step 1 – Divide the total batch gallons to be heated by the time (in minutes) required. This result is the gallons heated per minute.

Step 2 – Refer to the performance chart. In the column under required available operating steam pressure select the figure equal to or greater than the desired capacity. Check to determine if adequate temperature rise is possible with this size. If not, move down to a larger size.

Step 3 – If multiple units are desired, select several smaller heaters with a total capacity of that required.

Method 2 example

Though the following example illustrates the selection of a CTE2 heater

Operating conditions

Available steam pressure psig (h_m):	80
Desired temperature rise °F (ΔT):	40
Tank capacity, gallons:	10,000
Heating time, minutes:	35

Step 1 – $\frac{10,000}{35} = 286$ gallons heater per minute (ghpm)

Step 2 – From performance chart – under 80 psig steam pressure, go down the column to the capacity that is equal to or rater than required, to a row where T=40F. In this case the required capacity is 286 ghpm and the closest (higher) one is 315 ghpm in a 3" CTE2 heater.

Step 3 – If multiple units are required, try several smaller heaters, for example five 1 ½" units with 67 ghpm capacity: 5 x 67 = 335 ghpm total.

PENBERTHY SERIES ELL, HLM, SRH AND CTE2 FOR HEATING LIQUIDS
 HEATING LIQUIDS IN LINE

Table 16 – CTE2 PERFORMANCE (gallons heated per minute – ghpm)

Size	Temp. rise °F (ΔT)	Operating steam pressure (h _m)						
		20 psig	40 psig	60 psig	80 psig	100 psig	120 psig	140 psig
CTE								
3/8	10	24	37	51	64	77	90	103
	20	12	19	25	32	38	45	51
	40	6	9	13	16	19	22	26
	80	3	5	6	8	10	11	13
	120	2	3	4	5	6	8	9
3/4	10	51	78	106	133	160	187	214
	20	25	39	53	67	80	94	107
	40	13	20	27	33	40	47	54
	80	6	10	13	17	20	23	27
	120	4	7	9	11	13	16	18
1 1/2	10	103	158	215	270	324	380	434
	20	51	79	107	135	162	190	217
	40	26	40	54	67	81	95	108
	80	13	20	27	34	41	48	54
	120	9	13	18	23	27	32	36
2	10	203	214	425	534	642	752	859
	20	102	157	212	267	321	376	429
	40	51	78	106	133	160	188	215
	80	25	39	53	67	80	94	107
	120	17	26	35	44	54	63	72
3	10	481	741	1004	1261	1517	1777	2029
	20	240	371	502	631	758	888	1015
	40	120	185	251	315	379	444	507
	80	60	93	125	158	190	222	254
	120	40	62	84	105	126	148	169

Table 17 – CTE2 STEAM CONSUMPTION (lbs per minute using dry steam)

Size	Operating steam pressure (h _m)							
	10 psig	20 psig	40 psig	60 psig	80 psig	100 psig	120 psig	140 psig
	CTE							
3/8	1	2	3	4	5	6	7	8
3/4	2	4	6	9.5	11	13	16	18
1 1/2	4	8	13	19	22	27	32	36
2	6	17	26	36	44	63	63	71
3	20	40	52	86	106	126	148	169

PENBERTHY SERIES ELL, HLM, SRH AND CTE2 FOR HEATING LIQUIDS
 HEATING LIQUIDS IN LINE

Table 17 – CTE2 DIMENSIONS (in inches)

Heater size	A	C	D
3/8*	4 3/8	2 1/2	3/8
3/4*	7 3/8	3 3/4	3/4
1 1/2	11	5 1/2	1 1/2
2	14 5/8	7 3/4	2
3	22	11 3/4	3

*Male NPT

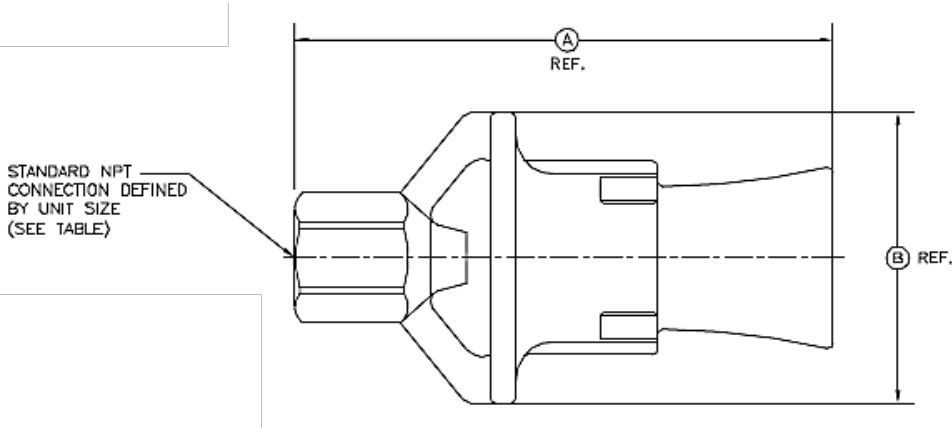

PENBERTHY SERIES ELL, HLM, SRH AND CTE2 FOR HEATING LIQUIDS
HEATING LIQUIDS IN LINE

PART NUMBER FOR NPT UNITS

EXTENDED PART NUMBER FOR FLANGED UNITS

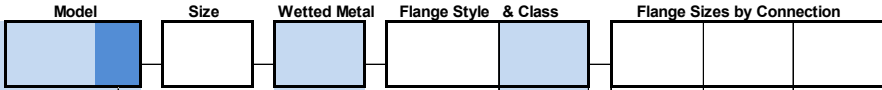

Connections: NPT (Standard)

Model	Code
LL	PLL-
LM	PLM-
LH	PLH-
GL	PGL-
GH	PGH-
ELL	PELL-
HLM	PHLM-
RJ	PRJ-

Flanged

Model Code Suffix

F

Example: **PLL-F-**

** 4" body is cast with flanges

--> use "F" only w/ flanged nozzle

Motive	Suction	Outlet
(use letter codes from table)		

Size	Letter Code
1/2"	D
3/4"	E
1"	F
1 1/4"	G
1 1/2"	H
2"	I
2-1/2"	J
3"	K
4"	L

Size	Code	Size	Code	Size	Code	Size	Code	Size	Code	Size	Code
1/2A	08A	1/2"	08	1"	12	1 1/2"	16	2 1/2"	20	4" **	24
1/2B	08B	3/4"	10	1 1/4"	14	2"	18	3"	22		

Note: Unit size is dictated by the body size. Standard units have the suction and outlet the same size.

Body Material	Code	Special Materials	Code	Plastic Materials	Code
Carbon Steel (WCB)	C	Hastelloy C (CW12MW)	H	PVC	P
316 SS (CF8M)	S	Alloy 20 (CN7M)	A	CPVC	CP
Bronze (B62)	B	Monel (M-35-1)	M	Polypropylene	PP
				PVDF (formerly Kynar)	K

Flange Style	Code
Weld Neck Flange	W
Slip-on Flange	

W = standard configuration

Note: Part combinations that cannot be defined here will be designated as "Special" and will have either an order based part number or a base part with "SP" included in the part number.

Flange Class	Code
CL150 ASME (B16.5)	(Blank)
CL300 ASME (B16.5)	3

Examples:

- 3/4" Model LM in bronze, standard connections
Part number: **PLM-10-B**
- 1-1/2" Model LH in carbon steel with CL150 flanges, WN style, with standard 1-1/4" x 1-1/2" x 1-1/2" connection sizes
Part number: **PLHJ-16-C-W-GHH**
- 2" Model GL in 316SS with CL300 flanges, WN style, with standard 1-1/2" x 2" x 2" connection sizes
Part number: **PGLF-18-S-W3-HII**
- 4" Model LM in carbon steel with standard NPT nozzle and CL150 flanged body (which is the only CL available for 4" body)
Part number: **PLM-24-C**
- 4" Model LM in carbon steel with flanged nozzle and CL150 flanged body (which is the only CL available for 4" body)
Part number: **PLMF-24-C-W-KLL**



PENBERTHY SERIES ELL, HLM, SRH AND CTE2 FOR HEATING LIQUIDS
HEATING LIQUIDS IN LINE

PART NUMBER FOR NPT UNITS

EXTENDED PART NUMBER FOR FLANGED UNITS

Model: SRH
Code: **PSRH-**

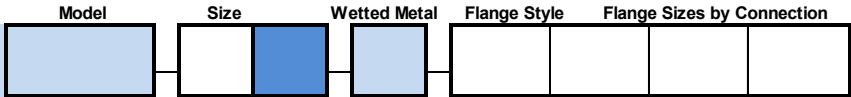

Size	Code	Inlet	Outlet	Steam
310	#	1 1/2"	1 1/2"	1"
320	#	2"	2"	1 1/4"
330	#	3"	3"	1 1/2"
340	# F	6" **	6" **	2"

Flanged Inlet, Outlet, or Steam

Model Code Suffix

F

Example: PSRHF-

** 340 body is cast with Inlet & Outlet flanges and an NPT steam connection

--> use "F" for 340 in all cases

Body Material	Code	Special Materials	Code
Carbon Steel (WCB)	C	Hastelloy C (CW12MW)	H
316 SS (CF8M)	S	Alloy 20 (CN7M)	A
Bronze (B62)	B	Monel (M-35-1)	M

Size	Letter Code
1/2"	D
3/4"	E
1"	F
1 1/4"	G
1 1/2"	H
2"	I
2-1/2"	J
3"	K
4"	L
6"	M
8"	N

(1) Use an "X" if the connection is threaded. (not flanged).

Flange Style	Code	Notes:
Cast Inlet & Outlet	C	Standard for 340, Option for 330
Weld Neck Flange	W	Option for Steel and 316
Slip-on Flange	S	Option for Steel and 316
Thread-on Flange	T	Option for Bronze

Note: Part combinations that cannot be defined here will be designated as "Special" and will have either an order based part number or a base part with "SP" included in the part number.

Examples:

- Size 31 Model SRH in bronze, standard connections (1 1/2" x 1 1/2" x 1")
Part number: **PSRH-31-B**
- Size 32 Model SRH in carbon steel, standard connections (2" x 2" x 1 1/4")
Part number: **PSRH-32-C**
- Size 33 Model SRH in 316 SS, Standard connections (3" x 3" x 1 1/2")
Part number: **PSRH-33-S**
- Size 33 Model SRH in Steel, Flanged inlet and outlet connections (3" x 3"), and a 1 1/2" flanged steam connection, all slip-on
Part number: **PSRH-33F-C-SKKI**
- Size 33 Model SRH in Bronze, Flanged inlet and outlet connections (3" x 3"), and a 1 1/2" NPT steam connection
Part number: **PSRH-33F-B-CKKX**
- Size 34 Model SRH in 316 SS, Standard connections (6" x 6" x 2")
Part number: **PSRH-34F-S-CMMX**
- Size 34 Model SRH in Steel, Standard inlet and outlet connections (6" x 6"), and a 2" flanged steam connections, threaded
Part number: **PSRH-34F-S-TMMX**
Since the 340 has cast flanges, but the steam can be standard NPT (X), then have a threaded (T) or slip-on (S). We will use the variable connection in the part number.



PENBERTHY SERIES ELL, HLM, SRH AND CTE2 FOR HEATING LIQUIDS
 HEATING LIQUIDS IN LINE

PART NUMBER FOR NPT UNITS

EXTENDED PART NUMBER FOR FLANGED UNITS

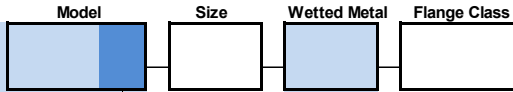

Connections: NPT (Standard)

Model	Code
CTE	PCTE2-

Flanged

Model Code Suffix

F

Example: PCTE2F-

** 4" body is made with flanges

--> Use "F" for 4" and Larger

Size	Code	Size	Code	Size	Code	Size	Code
3/4"	10	2"	18	4" **	24	8" **	30
1 1/2"	16	3"	22	6" **	28		

Note: Unit size is dictated by the body size. Standard units have the suction and outlet the same size.

Body Material	Code	Special Materials	Code	Plastic Materials	Code
Carbon Steel (WCB)	C	Hastelloy C (CW12MW)	H	PVC	P
316 SS (CF8M)	S	Alloy 20 (CN7M)	A	CPVC	CP
Bronze (B62)	B	Monel (M-35-1)	M	Polypropylene	PP
				PVDF (formerly Kynar)	K

Flange Class	Code
CL150 ASME (B16.5)	(Blank)
CL300 ASME (B16.5)	3

Note: Part combinations that cannot be defined here will be designated as "Special" and will have either an order based part number or a base part with "SP" included in the part number.

Examples:

- 3/4" Model CTE2 in bronze, standard connections
Part number: **PCTE2-10-B**
- 1-1/2" Model CTE2 in carbon steel with CL150 flanges, 1-1/2" connection size
Part number: **PCTE2-16-C**
- 2" Model CTE2 in 316SS with CL300 flanges, with standard 2" connection size
Part number: **PCTE2-18-S-3**
- 3" Model CTE2 in 316 SS with CL150 flanged connection size
Part number: **PCTE2F-22-S**
- 4" Model CTE2 in carbon steel CL150 flanged connection size
Part number: **PCTE2F-24-C**

Authorised Distributor:



46, Jalan SS 22/21, Damansara Jaya,
47400 Petaling Jaya,
Selangor Darul Ehsan, Malaysia.
Email: nog@nog.com.my
Website: www.nog.com.my

PENBERTHY®

16633 Foltz Parkway, Strongsville, OH 44149 USA • Telephone: +440-572-1500
www.PenberthyProcess.com • sales@PenberthyProcess.com