

PENBERTHY SERIES LL, LM, LH, GL and GH JET PUMPS FOR PUMPING LIQUIDS

Practical, simple and cost-effective alternatives for process industries to pump a range of liquids.



FEATURES

- Simple design with no moving parts to wear out.
- No lubrication required.
- Virtually maintenance-free.
- Easy to install without special structures or foundations.
- Self-priming
- Cast, fabricated or non-metallic constructions.
- Variety of materials to suit specific characteristics of the process liquids.
- Critical flow paths machined smoothly with no abrupt turns or steps, producing the most efficient flow during the motive function.

GENERAL APPLICATION

Suitable for a broad range of applications including: handling condensate, pumping wells, circulating solutions, emptying cesspools, pumping brine solutions, extracting solvents, draining cellars, pumping out barges, acidifying, causticizing oils, producing emulsions, elevation water.

TECHNICAL DATA

Materials:	Bronze, carbon steel, 316 SS, PVC, PP, PVDF
Sizes:	½" to 12"
Pressure Range:	15 to 200 psig (1 to 13.8 barg)
Temperature (max):	to 200°F (93°C)

PENBERTHY®

16633 Foltz Parkway, Strongsville, OH 44149 USA • Telephone: +440-572-1500
www.penberthyprocess.com • sales@penberthyprocess.com

PRODUCT OVERVIEW

There are two basic series of Penberthy jet pumps available for pumping liquids: The L Series has three models, the LL, LM and LH which use liquid as the operating medium. The G Series has two models, the GL and GH, using steam as the operating medium. Each of the five models is available in 15 different sizes, from 1/2" to 12.

OPERATION

All jet pumps operate on the principle of a fluid entraining a second fluid. Although design and construction may vary, this applies to all jet pumps.

All jet pumps have three common features: inlet, suction and discharge. They function as follows:

Inlet – The operating medium (liquid, steam or air) under pressure enters the inlet and travels through the nozzle into the suction chamber. The nozzle converts the pressure of the operating medium into a high velocity stream, which passes from the discharge side of the inlet nozzle.

Suction – Pumping action begins with vapor, gases or liquid in the suction chamber are entrained by the high velocity stream emerging from the inlet nozzle, lowering the pressure in the suction chamber. The resulting action causes the liquid, gas or vapor in the suction chamber to flow toward the discharge.

Discharge – The entrained material from the suction system mixes with the operating medium and acquires part of its energy in the parallel section. In the diffuser section, part of the velocity of the mixture is converted to a pressure greater than the suction pressure, but lower than the operating medium pressure.

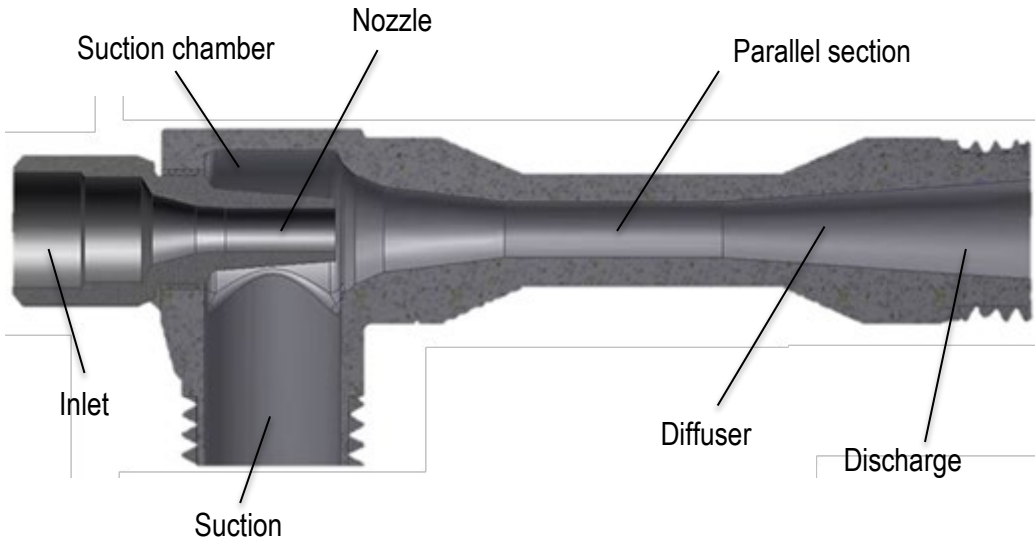

L SERIES SELECTION

L Series liquid operated jet pumps are available for low, medium and high discharge pressures.

Sizes available

Each model is available in 15 sizes from ½" to 12 suction and discharge. Units are cast construction in sizes ½ through 4. Sizes 4 through 12 are available with fabricated construction. Certain sizes of units are also available in PVC and other polymer constructions.

TABLE 1 - MODEL CONSTRUCTION DATA

Model	LL, LM, LH	Standard materials
Sizes available	½"A-4"	Cast: Bronze, carbon steel, 316 STS
	4" and up	Fabricated: Carbon steel, 316 STS
	½"A-3"	Non-metallic: PVC, PP, PVDF

MODEL SELECTION

The following information is needed for selection:

- Temperatures of operating suction liquids.
- Available operating liquid pressure, psig (h_m).
- Available flow of operating liquid, gpm (Q_m).
- Suction lift in feet of water (h_s).
- Discharge head in feet of water (h_d).
- Required pumping capacity, gpm (Q_s).
- Specific gravity of operating liquid.
- Specific gravity of suction liquid.
- Viscosity of operating liquid.
- Viscosity of suction liquid.

**PENBERTHY SERIES LL, LM, LH, GL AND GH JET PUMPS FOR PUMPING LIQUIDS
MODELS LL, LM, LH**

TABLE 2 - MODEL SPECIFICATIONS

Model	LL - Low head	LM - Medium head	LH - High head
Based on water at Sp. gr. = 1.0			
Motive medium pressure range	15-200 psig (100-1380 kPag)	15-200 psig (100-1380 kPag)	15-200 psig (100-1380 kPag)
Nominal motive medium pressure-psig/psig of discharge (kPag/kPag)	2 psig (15 kPag) (Sp. gr. 1.0)	1.5 psig (10 kPag) (Sp. gr. 1.0)	1 psig (7 kPag) (Sp. gr. 1.0)
Discharge head pressure range	to 50 ft. (15.2 m)-H ₂ O	40 to 80 ft. (12.2-24.4 m)-H ₂ O	80 ft. (24.4 m) or more-H ₂ O
Suction lift	up to 27 ft. (8.2 m)-H ₂ O	up to 27 ft. (8.2 m)-H ₂ O	up to 27 ft. (8.2 m)-H ₂ O
Minimum NPSH*	3 ft. (0.9 m)-H ₂ O	3 ft. (0.9 m)-H ₂ O	3 ft. (0.9 m)-H ₂ O

***How to calculate NPSH**

In the selection chart above, the operating liquid is assumed to be at ambient temperature. When the operating liquid is at higher temperature or when the vapor pressure is other than that of water, the liquid may vaporize within the jet pump and reduce pumping capacity.

For jet pumps, both motive and suction liquids must be considered for purposes of calculating net positive suction head (NPSH). Whichever liquid has the higher vapor pressure should be used as the basis of the calculation. Both liquids will be at the same temperature when they meet at the jet center line.

NPSH available is the dynamic pressure, in feet of liquid absolute, measured at the center line of the jet, less the vapor pressure. It must equal or exceed the NPSH that is required to achieve state performance.

To calculate NPSH for your application use the following formula:

$$NPSH = \frac{2.31(P_s - P_{vp})}{S_G} + h_s - H_f$$

- where:
- P_s = Pressure in the suction vessel in pounds per square inch absolute (psia).
 - P_{vp} = Vapor pressure of the pumped liquid in psia.
 - S_G = Specific Gravity of pumped liquid at pumping temp.
 - h_s = Feet that the fluid is below or above the jet pump center line (negative if below, positive if above).
 - H_f = Friction loss in the suction line (feet of liquid).

NPSH example calculation:

To pump water at 120°F with the surface of the water 12 feet below the jet pump center line:

- Fluid height (h_s): -12
- Vessel pressure (P_s): 14.7 psia
- Vapor Pressure (P_{vp}): 1.942 psia
- Friction loss (H_f): 1 foot
- Specific Gravity (S_G): 0.988

Using the formula given above:

$$NPSH = \frac{2.31(14.7 - 1.942)}{.988} + (-12) - 1$$

NPSH = 16.82 feet of water absolute

The feet of water supported by 14.7 psia minus NPSH equals suction lift in feet:

Suction lift = (2.31x14.7) – 16.82 = 17.1 feet of water.



L SERIES UNIT SELECTION USING PERFORMANCE CHARTS

To determine the correct jet pump, refer to the performance charts on pages 8 to 15.

Pumping liquids using liquid operating medium

Step 1 – Locate the suction lift (h_s) nearest to your application.

Step 2 – Locate discharge head (h_d).

Step 3 – Determine the amount of operating water pressure available. The data in the tables under each operating water value represents the amount of suction (water) flow (Q_s) for a 1 1/2" jet in each model (LL, LM, LH).

Step 4 – Determine the amount of operating water flow (Q_m) for a 1 1/2" jet in the three models.

Step 5 – Choose unit with suction flow GPM (Q_s) and operating water used (Q_m) matching your requirements.

Ideally, the unit selected should have the greatest suction capacity (Q_s) and consume the least operating liquid (Q_m). Try all three models in other sizes as shown in the example on page 4.

(The performance charts are based on 1 1/2" units).

Sizing for liquids example

To pump 12 gpm (Q_s) with:

Suction lift in feet (h_s):	-10
Discharge head in feet (h_d):	10
Operating water pressure psig (h_m):	50
Available operating water flow gpm (Q_m):	14

From the performance chart

All the values for Q_s found in step 3 for models LL, LM and LH exceed the desired Q_s of 12 gpm and Q_m of 14 gpm.

To find the size and model with the desired performance:

Find the capacity factor for LL:

$$Q_s \text{ (desired)} \div Q_s \text{ (for LL)} = 12 \div 21 = .571$$

Find this number or the next largest in the capacity factor table on page 7.

For an LL 1 1/4:

$$Q_s = 21 \times .613 = 12.87 \text{ gpm water pumped}$$

$$Q_m = 17 \times .613 = 10.42 \text{ gpm water used}$$

Repeat this procedure for all models LM and LH using the values of Q_s from step 3.

Then choose the model and size that operates closest to the desired performance:

For this application use LL 1 1/4. It pumps the most suction liquid ($Q_s = 12.87$ gpm) with the least operating liquid ($Q_m = 10.42$ gpm).

The effect of specific gravity and viscosity on jet pump performance

Fluid flow calculations indicate the effects of viscosity and specific gravity in fluid flow systems, as discussed below. The L Series performance data on pages 8 to 15 are based on water used as operating and suction liquids.

Specific gravity of water is 1 and viscosity is 1 centipoise (cP).

Viscosity of a fluid is a measure of shearing stress within the fluid, and a factor in system flow rates and pressure drops. The effect of viscosity on the performance of Penberthy jet pumps is negligible for viscosity values as high as 100 cP. For higher viscosity values, consult the factory.

Specific gravity of a liquid is the ratio of its weight per unit of volume to the weight per unit volume of water as standard conditions. Specific gravity values other than 1 will affect the performance of Penberthy liquid jet pumps, and require the following adjustments:

1. Operating medium flow rate – rate shown in the performance charts must be adjusted by multiplying the table values by $\sqrt{(1 \div SG)}$ (the specific gravity of actual operating fluid).
2. Suction flow rate – Suction lift and discharge head are given in feet of fluid flowing and must be converted to equivalent lift or head in terms of feet of water. Multiply the given lift or head by the specific gravity of the fluid at that condition. For calculation purposes, the suction lift is multiplied by the specific gravity of the suction fluid. The equivalent discharge head is calculated by averaging the specific gravity of the operating liquid flow and the suction flow. Multiply that average by the discharge head in feet.

Temperature and vapor pressure properties of liquids also affect performance. Most applications fall in range of 100°F inlet temperatures or less. For operating conditions outside these parameters, consult the factory.

**PENBERTHY SERIES LL, LM, LH, GL AND GH JET PUMPS FOR PUMPING LIQUIDS
MODELS LL, LM, LH**

L SERIES UNIT SELECTION USING PERFORMANCE CHARTS

Sizing for transporting solids

Penberthy jet pumps may be used to mix and transport the slurry of dry solids and liquids with a minimal volume of wash-down fluid. The following steps are provided for sizing:

- Step 1 – Determine operating flow in gpm by multiplying solids flow in ft³/min by 15 for model LM (by 8.33 for model LL).
- Step 2 – Determine hopper wash-down flow in gpm by multiplying solids flow in ft³/min by 7.5
- Step 3 – Determine operating pressure in psig by multiplying discharge head in feet by 2 for model LM (by 4 for model LL).
- Step 4 – Size the ejector using the performance chart on pages 10-11, under '0' suction lift (hs).

Sizing for solids example: consider the model LM

To pump 5 ft³/min of solids against 20 feet of discharge head:

- Step 1 – Determine operating flow: 5 x 15 = 75gpm
- Step 2 – Determine hopper wash-down flow: 5 x 7.5 = 37.5 gpm
- Step 3 – Determine operating pressure: 2 x 20 = 40 psig
- Step 4 – All Q values shown in the performance chart for model LM are lower than the desired operating flow of 75 gpm.

To find the size and model with the desired performance:

Find the capacity factor for LM:

$$Q_m (\text{desired}) \div Q_m (\text{for LM}) = 75 \div 24 = 3.125$$

Find this number or the next largest in the capacity factor table below (Table 4).

Capacity Factor = 3.17 for an LM 2½

For an LM 2½:

$$Q_s = 23 \times 3.17 = 72.9 \text{ gpm}$$

$$Q_m = 24 \times 3.17 = 76.0 \text{ gpm}$$

For this application use model LM 2½. It pumps the most suction slurry (Q_s = 72.9 gpm) with the least operating liquid (Q_m = 76.0).

Maximum particle clearance

L Series jet pumps can handle liquids bearing particulate matter or slurries.

The maximum particle size that can be passed in each is shown below.

TABLE 3 - PARTICLE SIZE (in inches)

Model	½A	½B	½	¾	1	1¼	1½	2	2½	3	4	6
LL	0.073	0.091	0.146	0.192	0.247	0.33	0.421	0.567	0.750	1.025	1.447	2.079
LM	0.065	0.081	0.129	0.170	0.218	0.291	0.372	0.501	0.663	0.906	1.276	1.834
LH	0.050	0.063	0.101	0.132	0.170	0.227	0.290	0.391	0.517	0.707	0.997	1.433

TABLE 4 - LL, LM, LH CAPACITY FACTOR

Size	Factor
½A	0.03
½B	0.047
½	0.121
¾	0.208
1	0.344
1¼	0.613
1½	1
2	1.82
2½	3.17
3	5.92
4	11.8
6	24
8	49
10	71
12	123



**PENBERTHY SERIES LL, LM, LH, GL AND GH JET PUMPS FOR PUMPING LIQUIDS
MODELS LL, LM, LH - PERFORMANCE**

TABLE 5 - 1½ LL, LM, LH PERFORMANCE (suction capacity Q_s in gpm)

Suction lift ft. (h _s)	Disch. hd. in feet (h _d)	Operating water pressure - psig (h _m)																							
		15			20			30			40			50			60			70			80		
		L	M	H	L	M	H	L	M	H	L	M	H	L	M	H	L	M	H	L	M	H	L	M	H
+10	0	51	39	41	51	43	41	51	46	40	51	46	39	51	45	39	51	45	38	51	45	38	50	44	37
	5	35	32	30	37	39	33	44	43	39	49	46	39	51	45	39	51	45	38	51	45	38	50	44	37
	10	14	18	19	21	20	25	32	35	34	39	43	39	46	45	39	51	45	38	51	45	38	50	44	37
	15	-	3	7	5	12	18	20	26	29	29	36	35	38	42	39	44	45	38	51	45	38	50	44	37
	20	-	-	-	-	4	9	7	17	23	20	28	31	29	36	39	36	45	38	43	45	38	49	44	37
	25	-	-	-	-	-	-	-	9	18	10	21	26	21	29	34	28	40	38	36	45	38	43	44	37
	30	-	-	-	-	-	-	-	-	12	-	13	22	12	23	30	20	34	38	29	39	38	36	44	37
	35	-	-	-	-	-	-	-	-	6	-	5	18	4	17	26	13	28	35	21	34	38	29	42	37
	40	-	-	-	-	-	-	-	-	1	-	-	14	-	10	22	5	22	21	14	29	38	22	37	37
	50	-	-	-	-	-	-	-	-	-	-	-	5	-	-	14	-	9	23	-	18	32	9	26	37
	60	-	-	-	-	-	-	-	-	-	-	-	-	-	-	6	-	-	15	-	8	25	-	16	33
	70	-	-	-	-	-	-	-	-	-	-	-	-	-	-	-	-	8	-	-	18	-	6	26	
	80	-	-	-	-	-	-	-	-	-	-	-	-	-	-	-	-	-	-	-	10	-	-	19	
	90	-	-	-	-	-	-	-	-	-	-	-	-	-	-	-	-	-	-	-	3	-	-	11	
	100	-	-	-	-	-	-	-	-	-	-	-	-	-	-	-	-	-	-	-	-	-	-	4	
	120	-	-	-	-	-	-	-	-	-	-	-	-	-	-	-	-	-	-	-	-	-	-	-	-
	140	-	-	-	-	-	-	-	-	-	-	-	-	-	-	-	-	-	-	-	-	-	-	-	-
	160	-	-	-	-	-	-	-	-	-	-	-	-	-	-	-	-	-	-	-	-	-	-	-	-
	180	-	-	-	-	-	-	-	-	-	-	-	-	-	-	-	-	-	-	-	-	-	-	-	-
+5	0	37	36	34	42	38	34	47	42	36	47	42	36	47	42	36	47	42	35	46	41	35	46	41	35
	5	20	23	23	26	28	26	35	38	33	43	42	36	47	42	36	47	42	35	46	41	35	46	41	35
	10	2	9	13	10	14	19	23	29	28	33	38	36	40	42	36	47	42	35	46	41	35	46	41	35
	15	-	-	3	-	6	12	11	20	23	23	31	31	31	37	36	39	42	35	44	41	35	46	41	35
	20	-	-	-	-	-	4	-	12	18	13	23	28	23	31	36	31	41	35	37	41	35	44	41	35
	25	-	-	-	-	-	-	-	3	12	3	16	23	14	25	31	23	35	35	30	41	35	37	41	35
	30	-	-	-	-	-	-	-	-	8	-	9	19	5	19	27	15	29	35	23	36	35	31	41	35
	35	-	-	-	-	-	-	-	-	2	-	1	15	-	13	23	7	23	33	16	31	35	24	38	35
	40	-	-	-	-	-	-	-	-	-	-	-	11	-	7	20	-	17	29	8	25	35	17	33	35
	50	-	-	-	-	-	-	-	-	-	-	-	2	-	-	12	-	5	21	-	15	29	4	23	35
	60	-	-	-	-	-	-	-	-	-	-	-	-	-	-	4	-	-	13	-	4	22	-	13	31
	70	-	-	-	-	-	-	-	-	-	-	-	-	-	-	-	-	-	5	-	-	15	-	3	24
	80	-	-	-	-	-	-	-	-	-	-	-	-	-	-	-	-	-	-	-	-	8	-	-	16
	90	-	-	-	-	-	-	-	-	-	-	-	-	-	-	-	-	-	-	-	-	1	-	-	10
	100	-	-	-	-	-	-	-	-	-	-	-	-	-	-	-	-	-	-	-	-	-	-	-	2
	120	-	-	-	-	-	-	-	-	-	-	-	-	-	-	-	-	-	-	-	-	-	-	-	-
	140	-	-	-	-	-	-	-	-	-	-	-	-	-	-	-	-	-	-	-	-	-	-	-	-
	160	-	-	-	-	-	-	-	-	-	-	-	-	-	-	-	-	-	-	-	-	-	-	-	-
	180	-	-	-	-	-	-	-	-	-	-	-	-	-	-	-	-	-	-	-	-	-	-	-	-
*		9.2	14	25	11	17	29	13	20	36	15	24	41	17	26	46	18	29	51	20	31	55	21	33	58

* OP. water used gpm (Q_m)



**PENBERTHY SERIES LL, LM, LH, GL AND GH JET PUMPS FOR PUMPING LIQUIDS
MODELS LL, LM, LH - PERFORMANCE**

TABLE 5 - 1½ LL, LM, LH PERFORMANCE (suction capacity Q_S in gpm) continued

Suction lift ft. (h _s)	Disch. h _d in feet (h _d)	Operating water pressure - psig (h _m)																				
		90			100			120			140			160			180			200		
		L	M	H	L	M	H	L	M	H	L	M	H	L	M	H	L	M	H	L	M	H
+10	0	49	44	37	48	44	37	48	44	37	48	44	37	48	44	37	48	44	37	48	44	37
	5	49	44	37	48	44	37	48	44	37	48	44	37	48	44	37	48	44	37	48	44	37
	10	49	44	37	48	44	37	48	44	37	48	44	37	48	44	37	48	44	37	48	44	37
	15	49	44	37	48	44	37	48	44	37	48	44	37	48	44	37	48	44	37	48	44	37
	20	49	44	37	48	44	37	48	44	37	48	44	37	48	44	37	48	44	37	48	44	37
	25	48	44	37	48	44	37	48	44	37	48	44	37	48	44	37	48	44	37	48	44	37
	30	42	44	37	46	44	37	48	44	37	48	44	37	48	44	37	48	44	37	48	44	37
	35	35	44	37	41	44	37	48	44	37	48	44	37	48	44	37	48	44	37	48	44	37
	40	29	44	37	36	44	37	48	44	37	48	44	37	48	44	37	48	44	37	48	44	37
	50	17	35	37	24	41	37	40	44	37	47	44	37	48	44	37	48	44	37	48	44	37
	60	-	25	37	12	32	37	28	44	37	37	44	37	48	44	37	48	44	37	48	44	37
	70	-	15	31	1	23	37	16	37	37	27	44	37	37	44	37	48	44	37	48	44	37
	80	-	5	25	-	13	33	3	28	37	17	42	37	27	44	37	38	44	37	46	44	37
	90	-	-	18	-	4	26	-	20	37	6	34	37	18	44	37	29	44	37	38	44	37
	100	-	-	12	-	-	20	-	11	34	-	26	37	8	39	37	19	44	37	30	44	37
	120	-	-	-	-	-	7	-	-	22	-	9	34	-	24	37	-	37	37	14	44	37
	140	-	-	-	-	-	-	-	-	10	-	-	24	-	8	35	-	21	37	-	34	37
	160	-	-	-	-	-	-	-	-	-	-	-	14	-	-	26	-	6	35	-	19	37
	180	-	-	-	-	-	-	-	-	-	-	-	3	-	-	15	-	-	25	-	-	35
+5	0	46	41	35	46	41	35	46	41	35	46	41	35	46	41	35	46	41	35	46	41	35
	5	46	41	35	46	41	35	46	41	35	46	41	35	46	41	35	46	41	35	46	41	35
	10	46	41	35	46	41	35	46	41	35	46	41	35	46	41	35	46	41	35	46	41	35
	15	46	41	35	46	41	35	46	41	35	46	41	35	46	41	35	46	41	35	46	41	35
	20	46	41	35	46	41	35	46	41	35	46	41	35	46	41	35	46	41	35	46	41	35
	25	43	41	35	46	41	35	46	41	35	46	41	35	46	41	35	46	41	35	46	41	35
	30	37	41	35	44	41	35	46	41	35	46	41	35	46	41	35	46	41	35	46	41	35
	35	31	41	35	38	41	35	46	41	35	46	41	35	46	41	35	46	41	35	46	41	35
	40	24	41	35	32	41	35	46	41	35	46	41	35	46	41	35	46	41	35	46	41	35
	50	12	32	35	20	38	35	34	41	35	43	41	35	46	41	35	46	41	35	46	41	35
	60	-	22	35	8	29	35	28	41	35	33	41	35	44	41	35	46	41	35	46	41	35
	70	-	13	30	-	19	35	11	34	35	22	41	35	34	41	35	43	41	35	46	41	35
	80	-	3	23	-	10	31	-	26	35	12	40	35	24	41	35	34	41	35	46	41	35
	90	-	-	17	-	1	24	-	17	35	2	31	35	14	41	35	35	41	35	36	41	35
	100	-	-	10	-	-	18	-	9	32	-	23	35	4	41	35	16	41	35	27	41	35
	120	-	-	-	-	-	5	-	-	21	-	7	33	-	21	35	-	34	35	11	41	35
	140	-	-	-	-	-	-	-	-	9	-	-	23	-	6	34	-	20	35	-	31	35
	160	-	-	-	-	-	-	-	-	-	-	-	20	-	-	24	-	5	34	-	17	35
	180	-	-	-	-	-	-	-	-	-	-	-	2	-	-	14	-	-	25	-	-	35
*		23	35	62	24	37	65	26	41	71	28	44	77	30	47	83	32	50	88	34	53	92

* OP. water used gpm (Q_m)



**PENBERTHY SERIES LL, LM, LH, GL AND GH JET PUMPS FOR PUMPING LIQUIDS
MODELS LL, LM, LH - PERFORMANCE**

TABLE 5 - 1½ LL, LM, LH PERFORMANCE (suction capacity Q_s in gpm) continued

Suction lift ft. (h _s)	Disch. hd. in feet (h _d)	Operating water pressure - psig (h _m)																							
		15			20			30			40			50			60			70			80		
		L	M	H	L	M	H	L	M	H	L	M	H	L	M	H	L	M	H	L	M	H	L	M	H
0	0	24	28	28	31	31	30	39	39	33	43	39	33	43	39	33	43	39	33	43	39	33	43	39	33
	5	7	15	18	16	23	23	29	32	30	36	39	33	43	39	33	43	39	33	43	39	33	43	39	33
	10	-	2	8	4	14	15	14	24	28	26	33	33	33	39	33	41	39	33	43	39	33	43	39	33
	15	-	-	-	-	6	8	2	15	20	16	31	30	25	33	33	33	39	33	39	39	33	43	39	33
	20	-	-	-	-	-	1	-	7	18	6	23	26	16	27	32	25	37	33	32	39	33	39	39	33
	25	-	-	-	-	-	-	-	-	10	-	11	21	8	21	29	17	31	33	24	38	33	32	39	33
	30	-	-	-	-	-	-	-	-	7	-	4	17	-	15	25	9	25	33	17	33	33	25	39	33
	35	-	-	-	-	-	-	-	-	-	-	-	13	-	9	21	-	19	30	1	27	33	10	36	33
	40	-	-	-	-	-	-	-	-	-	-	-	9	-	3	17	-	13	26	-	22	33	3	30	33
	50	-	-	-	-	-	-	-	-	-	-	-	1	-	-	10	-	-	19	-	12	27	-	20	33
	60	-	-	-	-	-	-	-	-	-	-	-	-	-	-	2	-	-	11	-	1	20	-	10	29
	70	-	-	-	-	-	-	-	-	-	-	-	-	-	-	-	-	-	3	-	-	13	-	-	22
	80	-	-	-	-	-	-	-	-	-	-	-	-	-	-	-	-	-	-	-	-	6	-	-	15
	90	-	-	-	-	-	-	-	-	-	-	-	-	-	-	-	-	-	-	-	-	-	-	-	8
	100	-	-	-	-	-	-	-	-	-	-	-	-	-	-	-	-	-	-	-	-	-	-	-	1
	120	-	-	-	-	-	-	-	-	-	-	-	-	-	-	-	-	-	-	-	-	-	-	-	-
	140	-	-	-	-	-	-	-	-	-	-	-	-	-	-	-	-	-	-	-	-	-	-	-	-
	160	-	-	-	-	-	-	-	-	-	-	-	-	-	-	-	-	-	-	-	-	-	-	-	-
	180	-	-	-	-	-	-	-	-	-	-	-	-	-	-	-	-	-	-	-	-	-	-	-	-
-5	0	14	19	22	20	23	25	31	35	31	38	35	31	39	35	31	40	35	31	40	35	31	40	36	31
	5	-	7	13	15	14	18	18	27	27	28	35	31	35	35	31	40	35	31	40	35	31	40	36	31
	10	-	-	4	-	9	11	6	18	22	18	28	30	27	34	31	35	35	31	40	35	31	40	36	31
	15	-	-	-	-	1	5	-	10	17	8	21	27	18	28	31	27	35	31	33	35	31	40	36	31
	20	-	-	-	-	-	-	-	2	12	-	14	24	10	23	29	19	34	31	26	35	31	33	36	31
	25	-	-	-	-	-	-	-	7	-	7	19	2	17	25	11	28	31	18	35	31	27	36	31	
	30	-	-	-	-	-	-	-	2	-	-	15	-	11	22	3	22	31	12	30	31	20	36	31	
	35	-	-	-	-	-	-	-	-	-	-	11	-	6	18	-	16	27	5	24	31	14	32	31	
	40	-	-	-	-	-	-	-	-	-	-	7	-	-	15	-	9	23	-	19	31	7	27	31	
	50	-	-	-	-	-	-	-	-	-	-	-	-	-	7	-	-	16	-	8	25	-	17	31	
	60	-	-	-	-	-	-	-	-	-	-	-	-	-	-	-	9	-	-	18	-	7	27	-	
	70	-	-	-	-	-	-	-	-	-	-	-	-	-	-	-	-	1	-	-	11	-	-	20	
	80	-	-	-	-	-	-	-	-	-	-	-	-	-	-	-	-	-	-	-	4	-	-	11	
	90	-	-	-	-	-	-	-	-	-	-	-	-	-	-	-	-	-	-	-	-	-	-	6	
	100	-	-	-	-	-	-	-	-	-	-	-	-	-	-	-	-	-	-	-	-	-	-	-	
	120	-	-	-	-	-	-	-	-	-	-	-	-	-	-	-	-	-	-	-	-	-	-	-	
	140	-	-	-	-	-	-	-	-	-	-	-	-	-	-	-	-	-	-	-	-	-	-	-	
	160	-	-	-	-	-	-	-	-	-	-	-	-	-	-	-	-	-	-	-	-	-	-	-	
	180	-	-	-	-	-	-	-	-	-	-	-	-	-	-	-	-	-	-	-	-	-	-	-	
*		9.2	14	25	11	17	29	13	20	36	15	24	41	17	26	46	18	29	51	20	31	55	21	33	58

* OP. water used gpm (Q_m)

**PENBERTHY SERIES LL, LM, LH, GL AND GH JET PUMPS FOR PUMPING LIQUIDS
MODELS LL, LM, LH - PERFORMANCE**

TABLE 5 - 1½ LL, LM, LH PERFORMANCE (suction capacity Q_s in gpm) continued

Suction lift ft. (h _s)	Disch. hd. in feet (h _d)	Operating water pressure - psig (h _m)																							
		90			100			120			140			160			180			200					
		L	M	H	L	M	H	L	M	H	L	M	H	L	M	H	L	M	H	L	M	H			
0	0	43	39	33	42	39	33	42	39	33	42	39	33	42	39	33	42	39	33	42	39	33	42	39	33
	5	43	39	33	42	39	33	42	39	33	42	39	33	42	39	33	42	39	33	42	39	33	42	39	33
	10	43	39	33	42	39	33	42	39	33	42	39	33	42	39	33	42	39	33	42	39	33	42	39	33
	15	43	39	33	42	39	33	42	39	33	42	39	33	42	39	33	42	39	33	42	39	33	42	39	33
	20	43	39	33	42	39	33	42	39	33	42	39	33	42	39	33	42	39	33	42	39	33	42	39	33
	25	39	39	33	42	39	33	42	39	33	42	39	33	42	39	33	42	39	33	42	39	33	42	39	33
	30	33	39	33	39	39	33	42	39	33	42	39	33	42	39	33	42	39	33	42	39	33	42	39	33
	35	19	39	33	33	39	33	33	39	33	42	39	33	42	39	33	42	39	33	42	39	33	42	39	33
	40	12	38	33	27	39	33	27	39	33	40	39	33	42	39	33	42	39	33	42	39	33	42	39	33
	50	8	29	33	15	35	33	29	39	33	39	39	33	42	39	33	42	39	33	42	39	33	42	39	33
	60	-	19	33	3	26	33	18	39	33	29	39	33	39	39	33	42	39	33	42	39	33	42	39	33
	70	-	10	29	-	16	33	6	32	33	19	39	33	29	39	33	40	39	33	42	39	33	42	39	33
	80	-	-	22	-	7	30	-	23	33	9	37	33	20	39	33	31	39	33	40	39	33	42	39	33
	90	-	-	15	-	-	24	-	15	33	-	29	33	10	39	33	21	39	33	31	39	33	31	39	33
	100	-	-	9	-	-	17	-	6	30	-	21	33	-	35	33	12	39	33	23	39	33	23	39	33
	120	-	-	-	-	-	4	-	-	19	-	4	32	-	19	33	-	34	33	6	39	33	6	39	33
	140	-	-	-	-	-	-	-	-	9	-	-	22	-	3	33	-	17	33	-	30	33	-	30	33
	160	-	-	-	-	-	-	-	-	-	-	-	12	-	-	23	-	2	33	-	15	33	-	15	33
	180	-	-	-	-	-	-	-	-	-	-	-	1	-	-	13	-	-	24	-	-	33	-	-	33
-5	0	40	36	31	40	36	31	40	36	31	40	36	31	40	36	31	40	36	31	40	36	31	40	36	31
	5	40	36	31	40	36	31	40	36	31	40	36	31	40	36	31	40	36	31	40	36	31	40	36	31
	10	40	36	31	40	36	31	40	36	31	40	36	31	40	36	31	40	36	31	40	36	31	40	36	31
	15	40	36	31	40	36	31	40	36	31	40	36	31	40	36	31	40	36	31	40	36	31	40	36	31
	20	40	36	31	40	36	31	40	36	31	40	36	31	40	36	31	40	36	31	40	36	31	40	36	31
	25	34	36	31	40	36	31	40	36	31	40	36	31	40	36	31	40	36	31	40	36	31	40	36	31
	30	28	36	31	34	36	31	40	36	31	40	36	31	40	36	31	40	36	31	40	36	31	40	36	31
	35	22	36	31	27	36	31	40	36	31	40	36	31	40	36	31	40	36	31	40	36	31	40	36	31
	40	16	35	31	22	36	31	35	36	31	40	36	31	40	36	31	40	36	31	40	36	31	40	36	31
	50	3	26	31	10	33	31	24	36	31	35	36	31	40	36	31	40	36	31	40	36	31	40	36	31
	60	-	16	31	-	23	31	13	36	31	25	36	31	34	36	31	40	36	31	40	36	31	40	36	31
	70	-	7	28	-	14	31	2	30	31	15	36	31	25	36	31	36	36	31	40	36	31	40	36	31
	80	-	-	21	-	4	28	-	24	31	5	36	31	16	36	31	27	36	31	36	36	31	36	36	31
	90	-	-	15	-	-	22	-	12	29	-	27	31	6	36	31	18	36	31	27	36	31	27	36	31
	100	-	-	8	-	-	16	-	2	18	-	19	31	-	32	31	8.6	36	31	18	36	31	18	36	31
	120	-	-	-	-	-	3	-	-	7	-	-	30	-	17	31	-	30	31	1	36	31	1	36	31
	140	-	-	-	-	-	-	-	-	-	-	-	20	-	1	31	-	15	31	-	28	31	-	28	31
	160	-	-	-	-	-	-	-	-	-	-	-	10	-	-	21	-	-	31	-	14	31	-	14	31
	180	-	-	-	-	-	-	-	-	-	-	-	-	-	-	12	-	-	24	-	-	31	-	-	31
*		23	35	62	24	37	65	26	41	71	28	44	77	30	47	83	32	50	88	34	53	92			

* OP. water used gpm [Q_m]

**PENBERTHY SERIES LL, LM, LH, GL AND GH JET PUMPS FOR PUMPING LIQUIDS
MODELS LL, LM, LH - PERFORMANCE**

TABLE 5 - 1½ LL, LM, LH PERFORMANCE (suction capacity Q_S in gpm) continued

Suction lift ft. (h _s)	Disch. h _d in feet (h _d)	Operating water pressure - psig (h _m)																							
		15			20			30			40			50			60			70			80		
		L	M	H	L	M	H	L	M	H	L	M	H	L	M	H	L	M	H	L	M	H	L	M	H
-10	0	4	13	17	11	18	22	22	29	26	32	32	27	36	32	27	36	32	27	36	32	27	36	32	27
	5	-	-	9	-	8	15	10	21	24	22	30	27	29	32	27	36	32	27	36	32	27	36	32	27
	10	-	-	1	-	-	9	-	14	19	12	24	26	21	31	27	29	32	27	35	32	27	36	32	27
	15	-	-	-	-	-	-	-	6	14	1	17	24	12	25	27	22	32	27	28	32	27	35	32	27
	20	-	-	-	-	-	-	-	-	9	-	10	20	4	19	27	14	30	27	21	32	27	28	32	27
	25	-	-	-	-	-	-	-	-	-	-	3	16	-	13	24	6	24	27	14	32	27	22	32	27
	30	-	-	-	-	-	-	-	-	-	-	-	12	-	7	21	-	18	27	7	27	27	15	32	27
	35	-	-	-	-	-	-	-	-	-	-	-	8	-	2	17	-	12	26	-	21	27	9	27	27
	40	-	-	-	-	-	-	-	-	-	-	-	4	-	-	14	-	6	22	-	16	27	-	23	27
	50	-	-	-	-	-	-	-	-	-	-	-	-	-	-	6	-	-	15	-	4	24	-	13	27
	60	-	-	-	-	-	-	-	-	-	-	-	-	-	-	-	-	-	7	-	-	17	-	3	25
	70	-	-	-	-	-	-	-	-	-	-	-	-	-	-	-	-	-	-	-	-	10	-	-	19
	80	-	-	-	-	-	-	-	-	-	-	-	-	-	-	-	-	-	-	-	-	3	-	-	12
	90	-	-	-	-	-	-	-	-	-	-	-	-	-	-	-	-	-	-	-	-	-	-	-	5
	100	-	-	-	-	-	-	-	-	-	-	-	-	-	-	-	-	-	-	-	-	-	-	-	-
	120	-	-	-	-	-	-	-	-	-	-	-	-	-	-	-	-	-	-	-	-	-	-	-	-
	140	-	-	-	-	-	-	-	-	-	-	-	-	-	-	-	-	-	-	-	-	-	-	-	-
	160	-	-	-	-	-	-	-	-	-	-	-	-	-	-	-	-	-	-	-	-	-	-	-	-
	180	-	-	-	-	-	-	-	-	-	-	-	-	-	-	-	-	-	-	-	-	-	-	-	-
-15	0	-	6	14	-	13	18	15	23	24	25	28	24	31	28	24	31	28	24	31	28	25	31	28	25
	5	-	-	-	-	4	12	4	16	21	15	26	24	23	28	24	31	28	24	31	28	25	31	28	25
	10	-	-	-	-	-	6	-	8	17	4	19	23	14	27	24	24	28	24	30	28	25	31	28	25
	15	-	-	-	-	-	-	-	-	12	-	12	21	6	21	24	16	28	24	23	28	25	30	28	25
	20	-	-	-	-	-	-	-	-	7	-	5	18	-	15	24	8	26	24	16	28	25	24	28	25
	25	-	-	-	-	-	-	-	-	-	-	14	-	9	24	-	20	24	9	28	25	17	28	25	
	30	-	-	-	-	-	-	-	-	-	-	10	-	3	19	-	14	24	2	23	25	11	28	25	
	35	-	-	-	-	-	-	-	-	-	-	6	-	-	15	-	8	24	-	17	25	5	25	25	
	40	-	-	-	-	-	-	-	-	-	-	3	-	-	12	-	2	21	-	12	25	-	20	25	
	50	-	-	-	-	-	-	-	-	-	-	-	-	-	5	-	-	13	-	1	23	-	10	25	
	60	-	-	-	-	-	-	-	-	-	-	-	-	-	-	-	-	6	-	-	16	-	-	25	
	70	-	-	-	-	-	-	-	-	-	-	-	-	-	-	-	-	-	-	-	9	-	-	17	
	80	-	-	-	-	-	-	-	-	-	-	-	-	-	-	-	-	-	-	-	2	-	-	16	
	90	-	-	-	-	-	-	-	-	-	-	-	-	-	-	-	-	-	-	-	-	-	-	5	
	100	-	-	-	-	-	-	-	-	-	-	-	-	-	-	-	-	-	-	-	-	-	-	-	
	120	-	-	-	-	-	-	-	-	-	-	-	-	-	-	-	-	-	-	-	-	-	-	-	
	140	-	-	-	-	-	-	-	-	-	-	-	-	-	-	-	-	-	-	-	-	-	-	-	
	160	-	-	-	-	-	-	-	-	-	-	-	-	-	-	-	-	-	-	-	-	-	-	-	
	180	-	-	-	-	-	-	-	-	-	-	-	-	-	-	-	-	-	-	-	-	-	-	-	
*		9.2	14	25	11	17	29	13	20	36	15	24	41	17	26	46	18	29	51	20	31	55	21	33	58

* OP. water used gpm [Q_m]



**PENBERTHY SERIES LL, LM, LH, GL AND GH JET PUMPS FOR PUMPING LIQUIDS
MODELS LL, LM, LH - PERFORMANCE**

TABLE 5 - 1½ LL, LM, LH PERFORMANCE (suction capacity Q_s in gpm) continued

Suction lift ft. (hs)	Disch. hd. in feet (hd)	Operating water pressure - psig (h _m)																				
		90			100			120			140			160			180			200		
		L	M	H	L	M	H	L	M	H	L	M	H	L	M	H	L	M	H	L	M	H
-10	0	36	32	28	36	32	28	36	32	28	36	32	28	36	32	28	36	32	28	36	32	28
	5	36	32	28	36	32	28	36	32	28	36	32	28	36	32	28	36	32	28	36	32	28
	10	36	32	28	36	32	28	36	32	28	36	32	28	36	32	28	36	32	28	36	32	28
	15	36	32	28	36	32	28	36	32	28	36	32	28	36	32	28	36	32	28	36	32	28
	20	35	32	28	36	32	28	36	32	28	36	32	28	36	32	28	36	32	28	36	32	28
	25	29	32	28	35	32	28	36	32	28	36	32	28	36	32	28	36	32	28	36	32	28
	30	23	32	28	30	32	28	36	32	28	36	32	28	36	32	28	36	32	28	36	32	28
	35	17	32	28	24	32	28	35	32	28	36	32	28	36	32	28	36	32	28	36	32	28
	40	10	31	28	18	32	28	29	32	28	36	32	28	36	32	28	36	32	28	36	32	28
	50	-	22	28	6	30	28	19	32	28	31	32	28	36	32	28	36	32	28	36	32	28
	60	-	13	28	-	20	28	8	32	28	21	32	28	31	32	28	36	32	28	36	32	28
	70	-	3	26	-	11	28	4	28	28	11	32	28	22	32	28	33	32	28	36	32	28
	80	-	-	19	-	1	28	-	19	28	1	32	28	12	32	28	23	32	28	36	32	28
	90	-	-	13	-	-	22	-	10	28	-	25	28	3	32	28	14	32	28	24	32	28
	100	-	-	7	-	-	15	-	1	28	-	17	28	-	30	28	8.6	32	28	15	32	28
	120	-	-	-	-	-	3	-	-	17	-	-	28	-	15	28	-	28	28	-	32	28
	140	-	-	-	-	-	-	-	-	6	-	-	11	-	-	28	-	13	28	-	26	28
	160	-	-	-	-	-	-	-	-	-	-	-	8	-	-	21	-	-	28	-	12	28
	180	-	-	-	-	-	-	-	-	-	-	-	-	-	-	12	-	-	23	-	-	28
-15	0	31	28	25	31	28	25	31	28	26	31	28	26	31	28	26	31	28	26	31	28	26
	5	31	28	25	31	28	25	31	28	26	31	28	26	31	28	26	31	28	26	31	28	26
	10	31	28	25	31	28	25	31	28	26	31	28	26	31	28	26	31	28	26	31	28	26
	15	31	28	25	31	28	25	31	28	26	31	28	26	31	28	26	31	28	26	31	28	26
	20	30	28	25	31	28	25	31	28	26	31	28	26	31	28	26	31	28	26	31	28	26
	25	24	28	25	31	28	25	31	28	26	31	28	26	31	28	26	31	28	26	31	28	26
	30	18	28	25	25	28	25	31	28	26	31	28	26	31	28	26	31	28	26	31	28	26
	35	12	28	25	19	28	25	30	28	26	31	28	26	31	28	26	31	28	26	31	28	26
	40	6	28	25	13	28	25	25	28	26	31	28	26	31	28	26	31	28	26	31	28	26
	50	-	19	25	2	27	25	15	28	26	31	25	26	31	28	26	31	28	26	31	28	26
	60	-	10	25	-	17	25	4	28	26	16	25	26	26	28	26	31	28	26	31	28	26
	70	-	-	25	-	8	25	-	24	26	7	25	26	17	28	26	26	28	26	31	28	26
	80	-	-	19	-	-	25	-	16	26	-	25	26	8	28	26	22	28	26	28	28	26
	90	-	-	12	-	-	21	-	7	26	-	22	26	-	28	26	12	28	26	20	28	26
	100	-	-	6	-	-	15	-	-	26	-	14	26	-	27	26	2	28	26	11	28	26
	120	-	-	-	-	-	2	-	-	16	-	-	26	-	12	26	-	26	26	-	28	26
	140	-	-	-	-	-	-	-	-	5	-	-	18	-	-	26	-	11	26	-	24	26
	160	-	-	-	-	-	-	-	-	-	-	-	8	-	-	21	-	-	26	-	10	26
	180	-	-	-	-	-	-	-	-	-	-	-	-	-	-	12	-	-	23	-	-	26
*		23	35	62	24	37	65	26	41	71	28	44	77	30	47	83	32	50	88	34	53	92

* OP. water used gpm (Q_m)



**PENBERTHY SERIES LL, LM, LH, GL AND GH JET PUMPS FOR PUMPING LIQUIDS
MODELS LL, LM, LH - PERFORMANCE**

TABLE 5 - 1½ LL, LM, LH PERFORMANCE (suction capacity Q_s in gpm) continued

Suction lift ft. (h _s)	Disch. hd. in feet (h _d)	Operating water pressure - psig (h _m)																							
		15			20			30			40			50			60			70			80		
		L	M	H	L	M	H	L	M	H	L	M	H	L	M	H	L	M	H	L	M	H	L	M	H
-20	0	-	-	11	-	18	16	7	19	20	18	24	20	27	24	20	27	24	21	27	24	22	27	24	22
	5	-	-	-	-	-	10	-	11	20	8	23	20	17	24	20	26	24	21	27	24	22	27	24	22
	10	-	-	-	-	-	3	-	4	16	-	15	20	8	23	20	18	24	21	25	24	22	27	24	22
	15	-	-	-	-	-	-	-	-	11	-	8	20	-	18	20	8	24	21	18	24	22	25	24	22
	20	-	-	-	-	-	-	-	-	6	-	1	16	-	12	20	-	21	21	11	24	22	19	24	22
	25	-	-	-	-	-	-	-	-	-	-	-	12	-	6	20	-	15	21	3	24	22	12	24	22
	30	-	-	-	-	-	-	-	-	-	-	-	8	-	1	18	-	10	21	-	20	22	6	24	22
	35	-	-	-	-	-	-	-	-	-	-	-	-	-	-	14	-	4	21	-	15	22	-	24	22
	40	-	-	-	-	-	-	-	-	-	-	-	-	-	-	11	-	-	20	-	10	22	-	15	22
	50	-	-	-	-	-	-	-	-	-	-	-	-	-	-	3	-	-	12	-	-	22	-	8	22
	60	-	-	-	-	-	-	-	-	-	-	-	-	-	-	-	-	5	-	-	15	-	-	-	22
	70	-	-	-	-	-	-	-	-	-	-	-	-	-	-	-	-	-	-	-	9	-	-	-	17
	80	-	-	-	-	-	-	-	-	-	-	-	-	-	-	-	-	-	-	-	2	-	-	-	10
	90	-	-	-	-	-	-	-	-	-	-	-	-	-	-	-	-	-	-	-	-	-	-	-	3
	100	-	-	-	-	-	-	-	-	-	-	-	-	-	-	-	-	-	-	-	-	-	-	-	-
	120	-	-	-	-	-	-	-	-	-	-	-	-	-	-	-	-	-	-	-	-	-	-	-	-
	140	-	-	-	-	-	-	-	-	-	-	-	-	-	-	-	-	-	-	-	-	-	-	-	-
	160	-	-	-	-	-	-	-	-	-	-	-	-	-	-	-	-	-	-	-	-	-	-	-	-
	180	-	-	-	-	-	-	-	-	-	-	-	-	-	-	-	-	-	-	-	-	-	-	-	-
-25	0	-	-	9	-	3	13	-	16	16	12	18	17	21	19	17	21	19	17	21	19	18	21	20	18
	5	-	-	-	-	-	7	-	8	16	1	17	17	11	19	17	19	19	17	20	19	18	21	20	18
	10	-	-	-	-	-	1	-	-	13	-	10	17	2	19	17	11	19	17	19	19	18	21	20	18
	15	-	-	-	-	-	-	-	-	8	-	4	17	-	14	17	3	19	17	13	19	18	20	20	18
	20	-	-	-	-	-	-	-	-	3	-	-	15	-	9	17	-	18	17	6	19	18	14	20	18
	25	-	-	-	-	-	-	-	-	-	-	-	11	-	3	17	-	12	17	-	19	18	7	20	18
	30	-	-	-	-	-	-	-	-	-	-	-	7	-	-	17	-	7	17	-	17	18	-	20	18
	35	-	-	-	-	-	-	-	-	-	-	-	4	-	-	13	-	2	17	-	12	18	-	20	18
	40	-	-	-	-	-	-	-	-	-	-	-	-	-	-	10	-	12	-	7	18	-	15	18	
	50	-	-	-	-	-	-	-	-	-	-	-	-	-	-	2	-	4	-	-	18	-	6	18	
	60	-	-	-	-	-	-	-	-	-	-	-	-	-	-	-	-	-	-	-	14	-	-	18	
	70	-	-	-	-	-	-	-	-	-	-	-	-	-	-	-	-	-	-	-	8	-	-	16	
	80	-	-	-	-	-	-	-	-	-	-	-	-	-	-	-	-	-	-	-	1	-	-	9	
	90	-	-	-	-	-	-	-	-	-	-	-	-	-	-	-	-	-	-	-	-	-	-	3	
	100	-	-	-	-	-	-	-	-	-	-	-	-	-	-	-	-	-	-	-	-	-	-	-	
	120	-	-	-	-	-	-	-	-	-	-	-	-	-	-	-	-	-	-	-	-	-	-	-	
	140	-	-	-	-	-	-	-	-	-	-	-	-	-	-	-	-	-	-	-	-	-	-	-	
	160	-	-	-	-	-	-	-	-	-	-	-	-	-	-	-	-	-	-	-	-	-	-	-	
	180	-	-	-	-	-	-	-	-	-	-	-	-	-	-	-	-	-	-	-	-	-	-	-	
*		9.2	14	25	11	17	29	13	20	36	15	24	41	17	26	46	18	29	51	20	31	55	21	33	58

* OP. water used gpm (Q_m)

**PENBERTHY SERIES LL, LM, LH, GL AND GH JET PUMPS FOR PUMPING LIQUIDS
MODELS LL, LM, LH - PERFORMANCE**

TABLE 5 - 1½ LL, LM, LH PERFORMANCE (suction capacity Q_s in gpm) continued

Suction lift ft. (h _s)	Disch. h _d in feet (h _d)	Operating water pressure - psig (h _m)																				
		90			100			120			140			160			180			200		
		L	M	H	L	M	H	L	M	H	L	M	H	L	M	H	L	M	H	L	M	H
-20	0	27	24	22	27	24	22	27	24	23	27	24	23	27	24	23	27	24	23	27	24	23
	5	27	24	22	27	24	22	27	24	23	27	24	23	27	24	23	27	24	23	27	24	23
	10	27	24	22	27	24	22	27	24	23	27	24	23	27	24	23	27	24	23	27	24	23
	15	27	24	22	27	24	22	27	24	23	27	24	23	27	24	23	27	24	23	27	24	23
	20	25	24	22	27	24	22	27	24	23	27	24	23	27	24	23	27	24	23	27	24	23
	25	19	24	22	26	24	22	27	24	23	27	24	23	27	24	23	27	24	23	27	24	23
	30	13	24	22	20	24	22	27	24	23	27	24	23	27	24	23	27	24	23	27	24	23
	35	8	24	22	15	24	22	24	24	23	27	24	23	27	24	23	27	24	23	27	24	23
	40	2	24	22	9	24	22	20	24	23	27	24	23	27	24	23	27	24	23	27	24	23
	50	-	16	22	-	24	22	10	24	23	21	24	23	27	24	23	27	24	23	27	24	23
	60	-	7	22	-	15	22	1	24	23	12	24	23	21	24	23	27	24	23	27	24	23
	70	-	-	22	-	6	22	-	22	23	-	24	23	13	24	23	22	24	23	27	24	23
	80	-	-	18	-	-	22	-	13	23	-	24	23	4	24	23	14	24	23	25	24	23
	90	-	-	12	-	-	20	-	4	23	-	19	23	-	24	23	6.4	24	23	16	24	23
	100	-	-	6	-	-	14	-	-	23	-	11	23	-	24	23	-	24	23	8	24	23
	120	-	-	-	-	-	1	-	-	16	-	-	23	-	9	23	-	23	23	-	24	23
	140	-	-	-	-	-	-	-	-	5	-	-	17	-	-	23	-	8	23	-	21	23
	160	-	-	-	-	-	-	-	-	-	-	-	7	-	-	21	-	-	23	-	7	23
	180	-	-	-	-	-	-	-	-	-	-	-	-	-	-	12	-	-	22	-	-	23
-25	0	21	20	18	21	20	18	21	20	19	21	20	19	21	20	19	21	20	19	21	20	19
	5	21	20	18	21	20	18	21	20	19	21	20	19	21	20	19	21	20	19	21	20	19
	10	21	20	18	21	20	18	21	20	19	21	20	19	21	20	19	21	20	19	21	20	19
	15	21	20	18	21	20	18	21	20	19	21	20	19	21	20	19	21	20	19	21	20	19
	20	20	20	18	21	20	18	21	20	19	21	20	19	21	20	19	21	20	19	21	20	19
	25	14	20	18	21	20	18	21	20	19	21	20	19	21	20	19	21	20	19	21	20	19
	30	9	20	18	16	20	18	21	20	19	21	20	19	21	20	19	21	20	19	21	20	19
	35	4	20	18	11	20	18	20	20	19	21	20	19	21	20	19	21	20	19	21	20	19
	40	-	20	18	5	20	18	16	20	19	21	20	19	21	20	19	21	20	19	21	20	19
	50	-	14	18	-	20	18	7	20	19	15	20	19	21	20	19	21	20	19	21	20	19
	60	-	4	18	-	13	18	-	20	19	8	20	19	17	20	19	21	20	19	21	20	19
	70	-	-	18	-	3	18	-	18	19	-	20	19	9	20	19	18	20	19	21	20	19
	80	-	-	18	-	-	18	-	10	19	-	20	19	1	20	19	10	20	19	21	20	19
	90	-	-	11	-	-	18	-	1	19	-	20	19	-	20	19	2.9	20	19	17	20	19
	100	-	-	5	-	-	14	-	-	19	-	9	19	-	20	19	-	20	19	4	20	19
	120	-	-	-	-	-	1	-	-	19	-	-	19	-	7	19	-	20	19	-	20	19
	140	-	-	-	-	-	-	-	-	16	-	-	17	-	-	19	-	5	19	-	18	19
	160	-	-	-	-	-	-	-	-	5	-	-	7	-	-	12	-	-	19	-	4	19
	180	-	-	-	-	-	-	-	-	-	-	-	-	-	-	2	-	-	19	-	-	19
*		23	35	62	24	37	65	26	41	71	28	44	77	30	47	83	32	50	88	34	53	92

* DP. water used gpm [Q_m]

PENBERTHY SERIES LL, LM, LH, GL AND GH JET PUMPS FOR PUMPING LIQUIDS
MODELS LL, LM, LH - PERFORMANCE

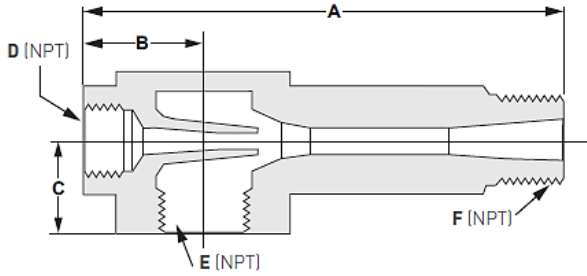

TABLE 6 - PVC - LL, LM, LH (in inches)

Size	Model	A	B	C	D	E	F
1/2 A	LL,LM,LH	3 3/4	1 11/16	15/16	1/4	1/2	1/2
1/2 B	LL,LM,LH	3 3/4	1 11/16	15/16	1/4	1/2	1/2
1/2	LL,LM,LH	4 5/8	1 11/16	15/16	1/4	1/2	1/2
3/4	LL,LM,LH	5 3/4	1 7/8	1	1/2	3/4	3/4
1	LL	6 7/8	2 1/8	1 5/16	1/2	1	1
1	LM,LH	6 7/8	2 1/8	1 5/16	3/4	1	1
1 1/4	LL	9 1/16	2 3/4	1 1/2	3/4	1 1/4	1 1/4
1 1/4	LM,LH	9 1/16	2 3/4	1 1/2	1	1 1/4	1 1/4
1 1/2	LL,LM	10 15/16	3	1 3/4	1	1 1/2	1 1/2
1 1/2	LH	10 15/16	3	1 3/4	1 1/4	1 1/2	1 1/2
2	LL,LM	14 3/16	3 1/2	1 15/16	1 1/4	2	2
2	LH	14 3/16	3 1/2	1 15/16	1 1/2	2	2
2 1/2	LL,LM	18 1/2	4	2 1/2	1 1/2	2 1/2	2 1/2
2 1/2	LH	18 1/2	4	2 1/2	2	2 1/2	2 1/2
3	LL,LM,LH	24 3/16	4 1/2	3	2	3	3

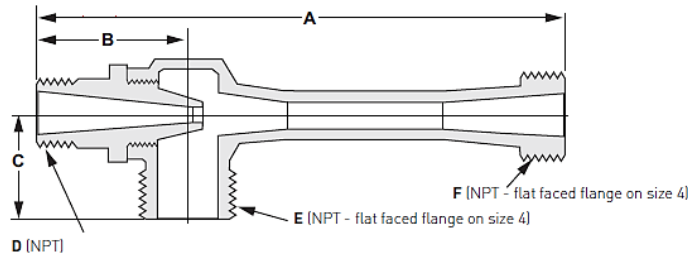

TABLE 7 - CAST - LL, LM, LH (in inches)

Size	Model	A	B	C	D	E	F
1/2 A	LL,LM,LH	4 3/8	1 1/2	1 1/4	1/4	1/2	1/2
1/2 B	LL,LM,LH	4 3/8	1 1/2	1 1/4	1/4	1/2	1/2
1/2	LL	4 1/2	1 5/8	1 1/4	1/4	1/2	1/2
	LM,LH	4 1/2	1 5/8	1 1/4	3/8	1/2	1/2
3/4	LL	5 7/8	2	1 1/2	3/8	3/4	3/4
	LM,LH	5 7/8	2	1 1/2	1/2	3/4	3/4
1	LL	7 1/8	2 1/4	1 3/4	1/2	1	1
	LM,LH	7 1/8	2 1/4	1 3/4	3/4	1	1
1 1/4	LL	9	2 1/2	2 1/4	3/4	1 1/4	1 1/4
	LM, LH	9	2 1/2	2 1/4	1	1 1/4	1 1/4
1 1/2	LL,LM	11	2 3/4	2 1/2	1	1 1/2	1 1/2
	LH	11	2 3/4	2 1/2	1 1/4	1 1/2	1 1/2
2	LL,LM	14 3/8	3 1/8	3	1 1/4	2	2
	LH	14 3/8	3 1/8	3	1 1/2	2	2
2 1/2	LL,LM	18 1/8	3 1/2	4 1/8	1 1/2	2 1/2	2 1/2
	LH	18 1/8	3 1/2	4 1/8	2	2 1/2	2 1/2
3	LL,LM,LH	23 7/8	4	5	2	3	3
4	LL,LM,LH	32 7/8	5	6	3	4❖	4❖

*Bolting corresponds to CL150 Flange per ASME B16.5.

❖ flange

**PENBERTHY SERIES LL, LM, LH, GL AND GH JET PUMPS FOR PUMPING LIQUIDS
MODELS LL, LM, LH - PERFORMANCE**

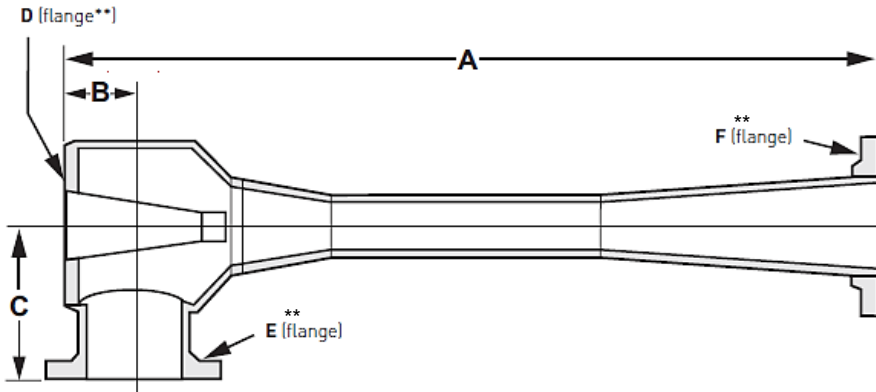

TABLE 8 - FABRICATED - LL, LM, LH (in inches)

Size	Model	A	B	C	D**	E	F
4	LL,LM,LH	38 ¹ / ₄	5 ¹ / ₄	8	3	4	4
6	LL,LM,LH	52 ⁷ / ₈	5 ⁷ / ₈	9 ¹ / ₂	4	6	6
8	LL,LM,LH	74 ⁷ / ₁₆	8 ⁷ / ₁₆	13	6	8	8
10	LL,LM,LH	87 ³ / ₈	10 ³ / ₈	14	8	10	10
12	LL,LM,LH	110 ³ / ₄	11 ³ / ₄	18	10	12	12

**Bolting corresponds to CL150 Flange per ASME B16.5. Bolt holes in D flange of all sizes are blind tapped.

G SERIES SELECTION

Pumping liquids using steam operating medium

G Series steam operated jet pumps are designed for low discharge head (Model GL) and high discharge head (Model GH) conditions to assure optimum performance over a wide range of operating conditions.

The following are general operating limits used in selecting individual units:

Model GL

For use with operating steam from 60 to 150 psig. Pumps against heads of one foot for each 3 psig operating pressure up to 50 feet discharge head. Suitable for lifts up to 20 feet. The pump will handle water up to 170°F with gravity flow to suction and discharge heads less than six feet. Maximum suction lift is 23 feet with from 60 to 90°F water.

Model GH

For use with operating steam between 35 and 150 psig. Pumps against heads of one foot for 1½ psig operating pressure. Designed for discharge heads over 50 feet. The GH model is suitable for lifts up to 20 feet. The pump will handle water up to 160°F with gravity flow to suction and discharge heads less than six feet.

Sizes available

Each model is available in 15 sizes from ½” to 12” suction and discharge. Units are cast construction in sizes ½ through 4. Sizes 4 through 12 are available with fabricated construction.

NOTE

Always specify material, model and unit size when ordering.

TABLE 9 - MODEL CONSTRUCTION DATA

Model	GL, GH	Standard materials
Sizes available	½”A-4”	Cast: Bronze, carbon steel, 316 STS
	4” and up	Fabricated: Carbon steel, 316 STS

TABLE 10 - MODEL SPECIFICATIONS

Model	GL- Low head	GH - High head
Motive medium	Steam	Steam
Motive steam pressure to elevate liquid 50 ft. (15.2 m)	150 psig (1035 kPag)	75 psig (520 kPag)
Motive steam pressure range	60 - 150 psig (415 - 1035 kPag)	35 - 150 psig (240 - 1035 kPag)
Suction lift - water temp. to 120°F (49°C)	up to 20 ft. (6.1 m)	up to 20 ft. (6.1 m)
Minimum NPSH*	13 ft. (4 m)	13 ft. (4 m)

* The process for calculating NPSH is explained on page 3

G SERIES UNIT SELECTION USING PERFORMANCE CHARTS

The following information is needed in determining the correct unit.

- Available operating steam pressure, psig (h_m)
- Available operating steam, lbs./min. (Q_m)
- Suction water temperature in °F (T_s)
- Suction lift in feet of water (h_s)
- Discharge head in feet of water (h_d)
- Required pumping capacity, gpm (Q_s)

Step 1 – Locate the suction lift (h_s) nearest your application.

Step 2 – Opposite the appropriate suction lift (h_s), locate discharge head (h_d).

Step 3 – Read to the right to the column that most closely approaches your suction water temperature (T_s) and operating steam pressure (h_m).

NOTE

Contrary to what may be expected, reducing steam pressure often increases capacity. Frequently, maximum economy can be gained by throttling the steam to its most efficient pressure.

The figures in this column of the table represent the suction capacity (Q_s), or amount of water that will be pumped by the 1½ size GL or GH unit respectively. The steam consumption chart shows the operating steam (Q_m) lbs./hr. for each model (GL, GH) at various pressures.

To find the size of a unit appropriate for your application, refer to the example shown.

Example:

To pump 52 gpm (Q_s) with:

Suction lift in feet (h_s):	-10
Operating steam pressure psig (h_m):	120
Suction water temperature °F (T_s):	120
Discharge head in feet (h_d):	30
Available motive steam lbs./min. (Q_m):	13.5
(Converted to lbs./hr.):	810

From performance chart

Locate the values for Q_s in the chart according to Steps 1, 2 and 3. In this case GL 1½ pumps 36 gpm (Q_s), which is closest to the desired rate of 52gpm. At 120 psig steam pressure, the GL 1½ uses 390 lbs./hr. operating steam. This indicates low pumping capacity. To achieve correct pumping capacity within available operating steam supply:

Find the capacity factor:

$$Q_s (\text{desired}) \div Q_s (\text{for GL}) = 52 \div 36 = 1.44$$

Find this number or the next largest in the capacity factor table on page 23 (Table 13).

Capacity factor = 1.82 for GL 2

For GL 2:

$$Q_s = 36 \times 1.82 = 65 \text{ gpm water pumped}$$

$$Q_m = 390 \times 1.82 = 710 \text{ lbs./hr. steam consumed}$$

Therefore, the GL 2 will exceed required capacity.

**PENBERTHY SERIES LL, LM, LH, GL AND GH JET PUMPS FOR PUMPING LIQUIDS
MODELS GL, GH - PERFORMANCE**

TABLE 11 - 1½ GL, GH PERFORMANCE (suction capacity Q_S in gpm)

Suction lift ft. (h _s)	Disch. h _d in feet (h _d)	Suction water temp. 80°F (T _s) operating steam pressure, psig (h _m)												Suction water temp. 120°F (T _s) operating steam pressure, psig (h _m)											
		35		60		80		100		120		150		35		60		80		100		120		150	
		GL	GH	GL	GH	GL	GH	GL	GH	GL	GH	GL	GH	GL	GH	GL	GH	GL	GH	GL	GH	GL	GH	GL	GH
+5	0	-	58	56	63	56	61	61	56	62	55	64	53	-	54	56	50	58	48	58	45	55	45	53	43
	5	-	54	47	63	56	61	61	56	62	55	64	53	-	54	56	50	58	48	58	45	55	45	53	43
	10	-	39	36	63	50	61	61	56	62	55	64	53	-	54	42	50	58	48	58	45	55	45	53	43
	15	-	23	24	63	42	61	56	56	62	55	64	53	-	54	29	50	48	48	58	45	55	45	53	43
	20	-	-	13	63	33	61	48	56	62	55	64	53	-	-	16	50	36	48	58	45	55	45	53	43
	25	-	-	-	57	25	61	40	56	54	55	64	53	-	-	-	50	24	48	47	45	55	45	53	43
	30	-	-	-	47	17	61	29	56	46	55	64	53	-	-	-	50	12	48	37	45	53	45	53	43
	40	-	-	-	27	-	51	17	56	32	55	52	53	-	-	-	25	-	48	15	45	27	45	53	43
	50	-	-	-	-	-	41	-	56	-	55	38	53	-	-	-	-	-	48	-	45	-	45	53	43
	60	-	-	-	-	-	-	-	56	-	55	24	53	-	-	-	-	-	-	-	45	-	45	-	43
	70	-	-	-	-	-	-	-	40	-	55	-	53	-	-	-	-	-	-	-	40	-	45	-	43
80	-	-	-	-	-	-	-	-	-	55	-	53	-	-	-	-	-	-	-	-	-	45	-	43	
100	-	-	-	-	-	-	-	-	-	-	-	53	-	-	-	-	-	-	-	-	-	-	-	43	
-5	0	-	52	47	51	54	51	55	48	57	44	57	39	-	42	48	37	47	37	44	36	42	34	42	30
	5	-	52	36	51	54	51	55	48	57	44	57	39	-	42	42	37	47	37	44	36	42	34	42	30
	10	-	39	26	51	43	51	55	48	57	44	57	39	-	42	29	37	47	37	44	36	42	34	42	30
	15	-	23	16	51	33	51	48	48	57	44	57	39	-	42	16	37	37	37	44	36	42	34	42	30
	20	-	-	-	51	23	51	40	48	52	44	57	39	-	-	-	37	24	37	44	36	42	34	42	30
	25	-	-	-	51	-	51	34	48	44	44	57	39	-	-	-	37	-	37	35	36	42	34	42	30
	30	-	-	-	47	-	51	21	48	37	44	57	39	-	-	-	37	-	37	25	36	42	34	42	30
	40	-	-	-	27	-	51	-	48	21	44	44	39	-	-	-	25	-	37	-	36	27	34	42	30
	50	-	-	-	-	-	41	-	48	-	44	29	39	-	-	-	-	-	37	-	36	-	34	27	30
	60	-	-	-	-	-	-	-	48	-	44	-	39	-	-	-	-	-	-	-	36	-	34	-	30
	70	-	-	-	-	-	-	-	40	-	44	-	39	-	-	-	-	-	-	-	36	-	34	-	30
80	-	-	-	-	-	-	-	-	-	44	-	39	-	-	-	-	-	-	-	-	-	-	-	30	
100	-	-	-	-	-	-	-	-	-	-	-	39	-	-	-	-	-	-	-	-	-	-	-	30	
-10	0	-	48	42	45	50	44	51	40	52	35	52	31	-	35	39	32	38	32	37	31	36	26	36	23
	5	-	48	30	45	48	44	51	40	52	35	52	31	-	35	35	32	38	32	37	31	36	26	36	23
	10	-	39	19	45	37	44	51	40	52	35	52	31	-	35	27	32	38	32	37	31	36	26	36	23
	15	-	23	-	45	27	44	43	40	52	35	52	31	-	35	16	32	29	32	37	31	36	26	36	23
	20	-	-	-	45	16	44	34	40	50	35	52	31	-	-	-	32	16	32	37	31	36	26	36	23
	25	-	-	-	45	-	44	25	40	41	35	52	31	-	-	-	32	-	32	28	31	36	26	36	23
	30	-	-	-	45	-	44	21	40	33	35	52	31	-	-	-	32	-	32	-	31	36	26	36	23
	40	-	-	-	27	-	44	-	40	-	35	41	31	-	-	-	25	-	32	-	31	-	26	36	23
	50	-	-	-	-	-	41	-	40	-	35	23	31	-	-	-	-	-	32	-	31	-	26	-	23
	60	-	-	-	-	-	-	-	40	-	35	-	31	-	-	-	-	-	-	-	31	-	26	-	23
	70	-	-	-	-	-	-	-	40	-	35	-	31	-	-	-	-	-	-	-	31	-	26	-	23
80	-	-	-	-	-	-	-	-	-	35	-	31	-	-	-	-	-	-	-	-	-	26	-	23	
100	-	-	-	-	-	-	-	-	-	-	-	31	-	-	-	-	-	-	-	-	-	-	-	23	



PENBERTHY SERIES LL, LM, LH, GL AND GH JET PUMPS FOR PUMPING LIQUIDS
 MODELS GL, GH - PERFORMANCE

TABLE 11 - 1½ GL, GH PERFORMANCE (suction capacity Q_s in gpm) continued

Suction lift ft. (h _s)	Disch. hd. in feet (h _d)	Suction water temp. 150°F (T _s) operating steam pressure, psig (h _m)											
		35		60		80		100		120		150	
		GL	GH	GL	GH	GL	GH	GL	GH	GL	GH	GL	GH
+5	0	-	30	47	35	42	34	41	33	41	33	41	-
	5	-	30	47	35	42	34	41	33	41	-	41	-
	10	-	30	47	35	42	34	41	33	41	-	41	-
	15	-	30	32	35	42	34	41	33	41	-	41	-
	20	-	30	-	35	42	34	41	33	41	-	41	-
	25	-	-	-	35	28	34	41	33	41	-	41	-
	30	-	-	-	35	-	34	41	33	41	-	41	-
	40	-	-	-	35	-	34	-	33	35	-	41	-
	50	-	-	-	-	-	34	-	33	-	-	41	-
	60	-	-	-	-	-	-	-	33	-	-	-	-
	70	-	-	-	-	-	-	-	33	-	-	-	-
80	-	-	-	-	-	-	-	-	-	-	-	-	
100	-	-	-	-	-	-	-	-	-	-	-	-	
-5	0	-	23	30	24	29	24	29	24	29	24	30	21
	5	-	23	30	24	29	24	29	24	29	-	30	-
	10	-	23	30	24	29	24	29	24	29	-	30	-
	15	-	23	-	24	29	24	29	24	29	-	30	-
	20	-	-	-	24	26	24	29	24	29	-	30	-
	25	-	-	-	24	-	24	29	24	29	-	30	-
	30	-	-	-	24	-	24	24	24	29	-	30	-
	40	-	-	-	24	-	24	-	24	19	-	30	-
	50	-	-	-	-	-	24	-	24	-	-	30	-
	60	-	-	-	-	-	-	-	24	-	-	-	-
	70	-	-	-	-	-	-	-	24	-	-	-	-
80	-	-	-	-	-	-	-	-	-	-	-	-	
100	-	-	-	-	-	-	-	-	-	-	-	-	
-10	0	-	16	23	17	22	18	24	19	23	16	23	-
	5	-	16	23	17	22	18	24	19	23	-	23	-
	10	-	16	23	17	22	18	24	19	23	-	23	-
	15	-	16	-	17	22	18	24	19	23	-	23	-
	20	-	-	-	17	-	18	24	19	23	-	23	-
	25	-	-	-	17	-	18	24	19	23	-	23	-
	30	-	-	-	17	-	18	-	19	23	-	23	-
	40	-	-	-	17	-	18	-	19	-	-	23	-
	50	-	-	-	-	-	18	-	19	-	-	-	-
	60	-	-	-	-	-	-	-	19	-	-	-	-
	70	-	-	-	-	-	-	-	19	-	-	-	-
80	-	-	-	-	-	-	-	-	-	-	-	-	
100	-	-	-	-	-	-	-	-	-	-	-	-	

**PENBERTHY SERIES LL, LM, LH, GL AND GH JET PUMPS FOR PUMPING LIQUIDS
MODELS GL, GH - PERFORMANCE**

TABLE 11 - 1½ GL, GH PERFORMANCE (suction capacity Q_S in gpm) continued

Suction lift ft. (h _s)	Disch. h _d in feet (h _d)	Suction water temp. 80°F (T _s) operating steam pressure, psig (h _m)												Suction water temp. 120°F (T _s) operating steam pressure, psig (h _m)											
		35		60		80		100		120		150		35		60		80		100		120		150	
		GL	GH	GL	GH	GL	GH	GL	GH	GL	GH	GL	GH	GL	GH	GL	GH	GL	GH	GL	GH	GL	GH	GL	GH
-15	0	-	40	36	37	45	36	46	31	45	26	43	23	-	26	31	26	30	26	30	21	30	17	30	15
	5	-	40	23	37	43	36	46	31	45	26	43	23	-	26	27	26	30	26	30	21	30	17	30	15
	10	-	30	-	37	30	36	46	31	45	26	43	23	-	26	-	26	30	26	30	21	30	17	30	15
	15	-	25	-	37	17	36	39	31	45	26	43	23	-	26	-	26	23	26	30	21	30	17	30	15
	20	-	-	-	37	-	36	29	31	45	26	43	23	-	-	-	26	-	26	30	21	30	17	30	15
	25	-	-	-	37	-	36	20	31	37	26	43	23	-	-	-	26	-	26	18	21	30	17	30	15
	30	-	-	-	37	-	36	-	31	27	26	43	23	-	-	-	26	-	26	-	21	27	17	30	15
	40	-	-	-	27	-	36	-	31	-	26	30	23	-	-	-	26	-	26	-	21	-	17	30	15
	50	-	-	-	-	-	36	-	31	-	26	-	23	-	-	-	26	-	26	-	21	-	17	-	15
	60	-	-	-	-	-	-	-	31	-	26	-	23	-	-	-	-	-	-	-	21	-	17	-	15
	70	-	-	-	-	-	-	-	31	-	26	-	23	-	-	-	-	-	-	-	21	-	17	-	15
	80	-	-	-	-	-	-	-	-	-	26	-	23	-	-	-	-	-	-	-	-	17	-	15	-
	100	-	-	-	-	-	-	-	-	-	-	-	23	-	-	-	-	-	-	-	-	-	-	15	-
-20	0	-	31	31	26	35	25	32	21	32	17	29	15	-	18	22	16	24	14	22	-	20	-	19	-
	5	-	31	-	26	35	25	32	21	32	17	29	15	-	18	12	16	24	14	22	-	20	-	19	-
	10	-	23	-	26	30	25	32	21	32	17	29	15	-	18	-	16	24	14	22	-	20	-	19	-
	15	-	-	-	26	17	25	32	21	32	17	29	15	-	18	-	16	24	14	22	-	20	-	19	-
	20	-	-	-	26	-	25	29	21	32	17	29	15	-	18	-	16	-	14	22	-	20	-	19	-
	25	-	-	-	26	-	25	-	21	32	17	29	15	-	-	-	16	-	14	-	-	20	-	19	-
	30	-	-	-	26	-	25	-	21	-	17	29	15	-	-	-	16	-	14	-	-	20	-	19	-
	40	-	-	-	-	-	25	-	21	-	17	-	15	-	-	-	-	-	-	-	-	-	19	-	
	50	-	-	-	-	-	-	-	21	-	17	-	15	-	-	-	-	-	-	-	-	-	-	-	-
	60	-	-	-	-	-	-	-	21	-	17	-	15	-	-	-	-	-	-	-	-	-	-	-	-
	70	-	-	-	-	-	-	-	21	-	17	-	15	-	-	-	-	-	-	-	-	-	-	-	-
	80	-	-	-	-	-	-	-	-	-	17	-	15	-	-	-	-	-	-	-	-	-	-	-	-
	100	-	-	-	-	-	-	-	-	-	-	-	15	-	-	-	-	-	-	-	-	-	-	-	-

TABLE 11 - 1½ GL, GH PERFORMANCE (suction capacity Q_S in gpm) continued

Suction lift ft. (h _s)	Disch. h _d in feet (h _d)	Suction water temp. 150°F (T _s) operating steam pressure, psig (h _m)											
		35		60		80		100		120		150	
		GL	GH	GL	GH	GL	GH	GL	GH	GL	GH	GL	GH
-15	0	-	-	16	-	14	-	16	-	16	-	15	-
	5	-	-	16	-	14	-	16	-	16	-	15	-
	10	-	-	-	-	14	-	16	-	16	-	15	-
	15	-	-	-	-	14	-	16	-	16	-	15	-
	20	-	-	-	-	-	-	16	-	16	-	15	-
	25	-	-	-	-	-	-	-	-	16	-	15	-
	30	-	-	-	-	-	-	-	-	16	-	15	-
	40	-	-	-	-	-	-	-	-	-	-	15	-
	50	-	-	-	-	-	-	-	-	-	-	-	-
	60	-	-	-	-	-	-	-	-	-	-	-	-
	70	-	-	-	-	-	-	-	-	-	-	-	-
	80	-	-	-	-	-	-	-	-	-	-	-	-
	100	-	-	-	-	-	-	-	-	-	-	-	-
-20	0	-	-	-	-	-	-	-	-	-	-	-	-
	5	-	-	-	-	-	-	-	-	-	-	-	-
	10	-	-	-	-	-	-	-	-	-	-	-	-
	15	-	-	-	-	-	-	-	-	-	-	-	-
	20	-	-	-	-	-	-	-	-	-	-	-	-
	25	-	-	-	-	-	-	-	-	-	-	-	-
	30	-	-	-	-	-	-	-	-	-	-	-	-
	40	-	-	-	-	-	-	-	-	-	-	-	-
	50	-	-	-	-	-	-	-	-	-	-	-	-
	60	-	-	-	-	-	-	-	-	-	-	-	-
	70	-	-	-	-	-	-	-	-	-	-	-	-
	80	-	-	-	-	-	-	-	-	-	-	-	-
	100	-	-	-	-	-	-	-	-	-	-	-	-



**PENBERTHY SERIES LL, LM, LH, GL AND GH JET PUMPS FOR PUMPING LIQUIDS
MODELS GL, GH – PERFORMANCE, DIMENSIONS**

TABLE 12 - 1½ GL,GH STEAM CONSUMPTION (lbs./hr. Q_m)

Steam Pres.	35	60	80	100	120	150
GL		221	277	333	390	474
GH	335	497	623	750	878	1067

TABLE 13 - GL, GH CAPACITY FACTOR

Size	Factor
½ A	0.03
½ B	0.047
½	0.121
¾	0.208
1	0.344
1¼	0.613
1½	1
2	1.82
2½	3.17
3	5.92
4	11.8
6	24
8	49
10	71
12	123

MAXIMUM PARTICLE CLEARANCE

The GL and GH Models can handle liquids bearing particulate matter or slurries. The following table shows maximum particle size that can be passed in each.

TABLE 14 - MAXIMUM PARTICLE CLEARANCE (in inches)

Size	½ A	½ B	½	¾	1	1¼	1½	2	2½	3	4	6
GL	0.097	0.122	0.195	0.256	0.329	0.439	0.561	0.756	0.999	1.365	1.926	2.767
GH	0.057	0.071	0.114	0.15	0.193	0.258	0.329	0.444	0.587	0.801	1.131	1.625

DIMENSIONS

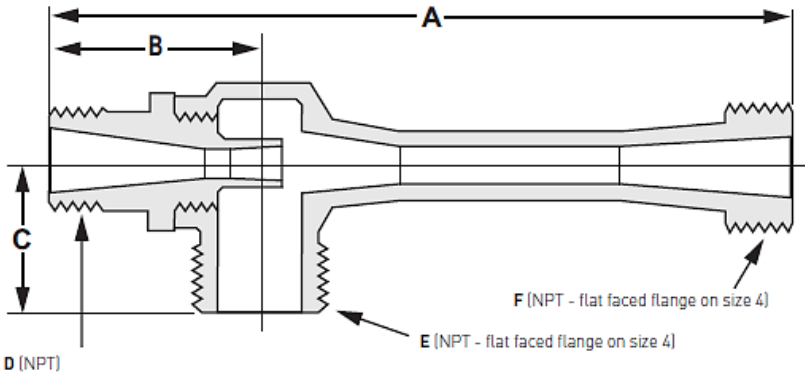

TABLE 15 - CAST GL, GH DIMENSIONS (in inches)

Size	A	B	C	D*	E*	F*
½ A	4¾	1½	1¼	¼	½	½
½ B	4¾	1½	1¼	¼	½	½
½	4½	1¾	1¼	¾	½	½
¾	5¾	2	1½	½	¾	¾
1	7¼	2¼	1¾	¾	1	1
1¼	9	2½	2¼	1	1¼	1¼
1½	11	2¾	2½	1	1½	1½
2	14¾	3¾	3	1¼	2	2
2½	18¾	3½	4¾	1½	2½	2½
3	23¾	4	5	2	3	3
4	32¾	5	6	3	4❖	4❖

❖ flange

**Bolting corresponds to CL150 Flange per ASME B16.5.

**PENBERTHY SERIES LL, LM, LH, GL AND GH JET PUMPS FOR PUMPING LIQUIDS
MODELS GL, GH – DIMENSIONS**

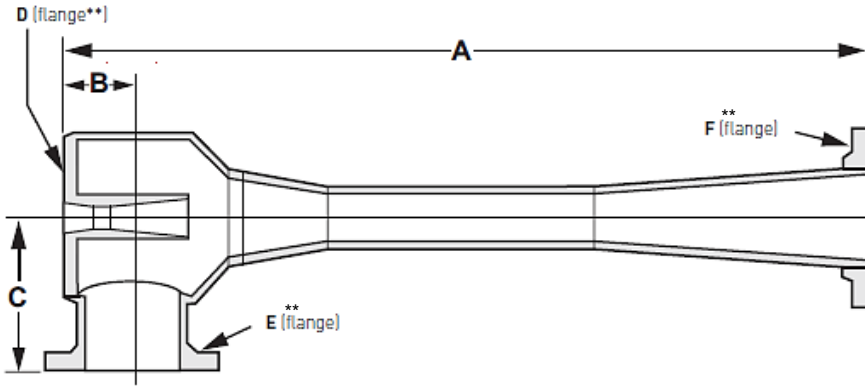

TABLE 16 - FABRICATED - GL, GH DIMENSIONS (in inches)

Size	A	B	C	D**	E	F
4	38 1/4	5 1/4	8	3	4	4
6	52 7/8	5 7/8	9 1/2	4	6	6
8	74 7/16	8 7/16	13	6	8	8
10	87 3/8	10 3/8	14	8	10	10
12	110 3/4	11 3/4	18	10	12	12

**Bolting corresponds to CL150 Flange per ASME B16.5. Bolt holes in D flange of all sizes are blind tapped.

Authorised Distributor:



**NATIONWIDE
OIL & GAS**

46, Jalan SS 22/21, Damansara Jaya,
47400 Petaling Jaya,
Selangor Darul Ehsan, Malaysia.
Email: nog@nog.com.my
Website: www.nog.com.my

PENBERTHY®

16633 Foltz Parkway, Strongsville, OH 44149 USA • Telephone: +440-572-1500
www.penberthyprocess.com • sales@penberthyprocess.com