

PENBERTHY SERIES LM, ELL, GL AND GH FOR PUMPING GASES

Practical, simple and cost-effective alternatives for process industries to pump a range of liquids.



*Product images are for reference only, please refer to general or approval drawings for accurate dimensions.

FEATURES

- Simple design with no moving parts to wear out.
- No lubrication required.
- Virtually maintenance-free.
- Easy to install without special structures or foundations.
- Self-priming
- Cast, fabricated or non-metallic constructions.
- Variety of materials to suit specific characteristics of the process liquids.
- Critical flow paths machined smoothly with no abrupt turns or steps, producing the most efficient flow during the motive function.

GENERAL APPLICATION

Applications include creating vacuums, exhausting vapors from process systems, evacuating tanks and vessels, scrubbing a gas to remove contaminants, priming, fume removal, fluid concentration, humidifying and condensing, drying, distilling and deaerating gas.

TECHNICAL DATA

Materials:	Bronze, carbon steel, 316 SS, PVC, PP, PVDF
Sizes:	½" to 12"
Pressure Range:	20 to 200 psig (1.38 to 13.8 barg)
Temperature (max):	to 200°F (93 ° C)

PENBERTHY®

16633 Foltz Parkway, Strongsville, OH 44149 USA • Telephone: +440-572-1500
www.PenberthyProcess.com • sales@PenberthyProcess.com

PRODUCT OVERVIEW

There are eight models of Penberthy jet pumps available for pumping gases:

Models LM and ELL are used for exhausting, evacuating and priming operations where a liquid operating medium is available. They are available with suction and discharge fittings ranging from ½” to 12”, depending on the type of construction.

GL and GH models are used for exhausting, evacuating and priming applications using operating steam or air in sizes from ½” to 12”.

TABLE 1 – MODEL SPECIFICATIONS

Model	LM	ELL	GL	GH
Motive medium	Liquid	Liquid	Steam, gas	Steam, gas
	20-200 psig	20-200 psig	60-120 psig	20-80 psig
Motive medium pressure range	(140-1380 kPag)	(140-1380 kPag)	(415-830 kPag)	(140-550 kPag)
Application range, inches Hg Abs (kg/cm ² Abs)	1-27 (.03-.93)	1-27 (.03-.93)	6-30 (.18-1.04)	6.5-30 (.2-1.04)
Functions	Evac/Exh/Prime	Evac/Exh/Prime	Evac/Exh/Prime	Evac/Exh/Prime

OPERATION

All jet pumps operate on the principle of a fluid entraining a second fluid. Although design and construction may vary, this applies to all jet pumps.

All jet pumps have three common features: inlet, suction and discharge. They function as follows:

Inlet – The operating medium (liquid, steam or air) under pressure enters the inlet and travels through the nozzle into the suction chamber. The nozzle converts the pressure of the operating medium into a high velocity stream, which passes from the discharge side of the inlet nozzle.

Suction – Pumping action begins with vapor, gases or liquid in the suction chamber are entrained by the high velocity stream emerging from the inlet nozzle, lowering the pressure in the suction chamber. The resulting action causes the liquid, gas or vapor in the suction chamber to flow toward the discharge.

Discharge – The entrained material from the suction system mixes with the operating medium and acquires part of its energy in the parallel section. In the diffuser section, part of the velocity of the mixture is converted to a pressure greater than the suction pressure, but lower than the operating medium pressure.

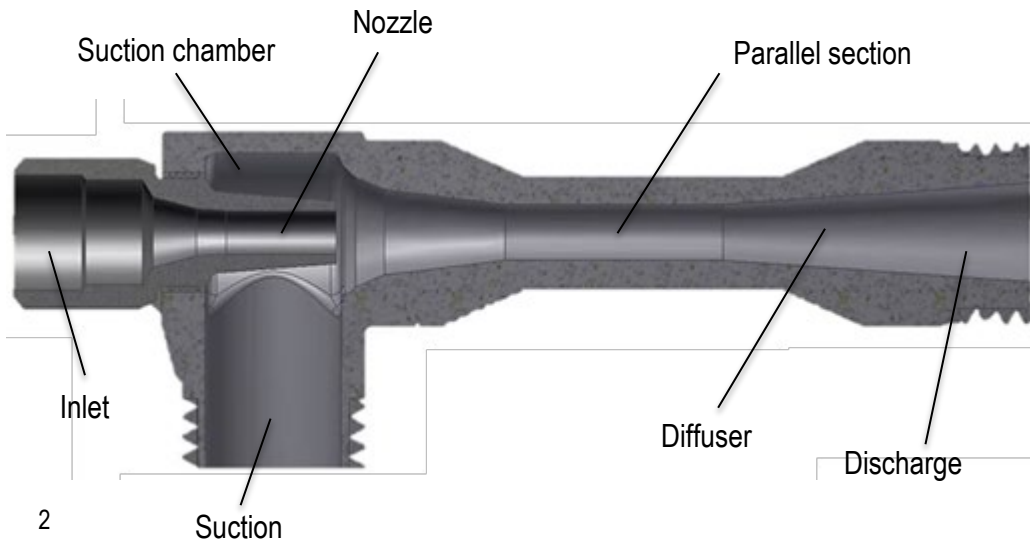

PUMPING GASES USING LIQUID OPERATING MEDIUM

The LM and ELL jet pumps are used for exhausting, evacuating and priming operations where a liquid operating medium is available in a 20 to 200 psig pressure range.

The maximum vacuum with closed suction is one inch Hg abs. These models are available with suction and discharge fittings ranging from 1/2" to 12", depending on the type of construction.

The ELL is well suited for moving air at a suction pressure of 1/2 to 1/10 atmospheric pressure.

TABLE 3 – MODEL CONSTRUCTION DATA

Model	LM, ELL	Standard Materials
Sizes available	1/2A - 4"	Cast: Bronze, Carbon steel, 316 STS
	4" and up	Fabricated: Carbon steel, 316 STS
	1/2A - 3"	Non-Metallic: PVC, PP, PVDF

PUMPING GASES USING LIQUID OPERATING MEDIUM

Evacuating and priming* (Models LM, ELL)

First determine:

- Volume of space to be evacuated – ft³:
- Required evacuation time – minutes:
- Operating liquid pressure – psig (h_m):
- Discharge pressure required – psig (h_d):
(Refer to LM, ELL evacuation time chart)

Example
30 ft³
3 min.
80 psig
atmospheric

Step 1 – Determine evacuation time in minutes per 10 ft³ or 100ft³ depending on volume of space to be evacuated (in this case, 30 ft³ – otherwise expressed as .3 hundred ft³).

$$32.5 \text{ (gpm operating water used)} \times \frac{1.82}{\text{(C.F.)}} = 59.2 \text{ actual water consumption}$$

$$\frac{\text{Required time to evacuate (3 mins)}}{\text{Evacuation time/100 ft}^3 \text{ (.3)}} = 10 \text{ min/100 ft}^3$$

* Priming: The procedure for selecting jet pumps for priming applications is the same as that for evacuation except: it takes twice the time to prime the same volume that can be evacuated with a given jet.

Step 2 – Locate operating water pressure (in this case 80 psig) and suction pressure (in this case 5" hg abs) on the left side of the chart.

Step 3 – Following along the appropriate line into the '100 ft³ evacuated' section, find the evacuation time that's 'equal to or lower than' the evacuation time required expressed in minutes/100 ft³ (in this case 10 minutes for ELL 2).

Step 4 – Continuing to the right on the same line, you'll find the operating water used for the selected model (in this case 32.5 gpm for the ELL 1 1/2) Then multiply this figure times the ELL 2 capacity factor (C.F.) to determine the actual water consumption of the selected unit.

TABLE 4 - LM, ELL EVACUATION TIME

Operating water pressure (h _m) psig	Suction pressure Hg. Abs (h _s)	Time in minutes per														Operating water used, gpm (Q _m) 1 1/2"							
		10 cubic feet evacuated				100 cubic feet evacuated																	
		1/2 A		1/2 B		1/2"		3/4"		1"		1 1/2"		1 1/2"				2"		2 1/2"		3"	
20	25"	24	13	15	8.3	59	32	34	19	21	11	12.00	6.4	7.10	3.9	3.90	2.10	2.20	1.20	1.20	0.66	17.5	17.2
	20"	87	50	55	32	215	123	125	72	76	43	43.00	24.0	26.00	15.0	14.00	8.20	8.20	4.70	4.40	2.50	18.4	18.1
	15"	180	107	114	68	448	264	260	154	157	93	88.00	52.0	54.00	32.0	30.00	18.00	17.00	10.00	9.10	5.40	19.2	18.8
	10"	-	-	-	-	826	-	481	-	291	-	-	-	100.00	-	55.00	-	31.00	-	17.00	-	20.0	-
40	25"	8.3	6	5.3	3.8	21	15	12	8.7	7.3	5.2	4.10	2.9	2.50	1.8	1.40	0.99	0.79	0.57	0.42	0.30	24.2	23.0
	20"	33	22	21	14	83	55	48	32	29	19	16.00	11.0	10.00	6.7	5.60	3.70	3.20	2.10	1.70	1.10	24.8	23.6
	15"	83	50	53	32	208	124	121	72	73	43	41.00	24.0	25.00	15.0	14.00	8.20	7.90	4.70	4.20	2.50	25.4	24.2
	10"	157	90	100	57	392	223	228	130	138	78	77.00	44.0	47.00	27.0	26.00	15.00	15.00	8.50	8.00	4.50	26.0	24.7
	5"	320	163	204	104	793	405	461	236	279	143	-	80.0	96.00	49.0	53.00	27.00	30.00	15.00	16.00	8.30	26.6	25.3
60	25"	3.7	4.7	2.3	3	9.1	12	5.3	6.7	3.2	4.1	1.80	2.3	1.10	1.4	0.60	0.77	0.35	0.44	0.18	0.24	29.4	27.3
	20"	17	14	11	9.1	41	36	24	21	14	12	8.10	7.0	5.00	4.3	2.70	2.40	1.60	1.30	0.84	0.72	30.0	27.8
	15"	43	30	28	19	110	74	64	43	39	26	22.00	15.0	13.00	8.9	7.30	4.90	4.20	2.80	2.20	1.50	30.5	28.3
	10"	97	50	62	32	240	124	139	72	84	44	47.00	24.0	29.00	15.0	16.00	8.20	9.10	4.70	4.90	2.50	30.9	28.7
	5"	207	87	132	55	512	215	298	125	180	76	-	43.0	62.00	26.0	34.00	14.00	19.00	8.20	10.00	4.40	31.4	29.2
80	25"	2.3	3.7	1.5	2.3	5.8	9.1	3.4	5.3	2	3.2	1.10	1.8	0.70	1.1	0.38	0.60	0.22	0.35	0.11	0.18	33.8	30.9
	20"	11	11	7	7	27	27	15.9	16	9.6	9.5	5.40	5.3	3.30	3.3	1.80	1.80	1.00	1.00	0.55	0.55	34.2	31.3
	15"	26	22	17	14	64	54	37.5	31	23	19	13.00	11.0	7.80	6.5	4.30	3.60	2.40	2.00	1.30	1.10	34.7	31.7
	10"	60	37	38	23	153	91	89	53	54	31	30.00	17.0	18.00	11.0	10.00	5.90	5.80	3.40	3.10	1.80	35.1	32.1
	5"	143	60	91	38	355	149	207	87	125	54	70.00	30.0	43.00	18.0	24.00	10.00	13.00	5.80	7.20	3.10	35.6	32.5
100	25"	2.2	3.3	1.4	2.1	5.4	8.3	3.1	4.8	1.9	2.9	1.10	1.6	0.65	1.0	0.36	0.55	0.20	0.31	0.11	0.17	37.7	34.0
	20"	7.7	9	4.9	5.7	19	22	11	13	6.7	7.9	3.70	4.4	2.30	2.7	1.30	1.50	0.72	0.86	0.39	0.46	38.1	34.4
	15"	19	18	12	11	48	44	28	25	17	15	9.50	8.7	5.80	5.3	3.20	2.90	1.80	1.70	0.98	0.90	38.5	34.7
	10"	40	29	25	19	99	73	58	42	35	25	20.00	14.0	12.00	8.8	6.60	4.80	3.80	2.80	2.00	1.50	38.9	35.1
	5"	100	50	64	32	249	124	145	72	88	44	49.00	25.0	30.00	15.0	17.00	8.30	9.50	4.70	5.10	2.50	39.3	35.4
140	25"	2	2.7	1.3	1.7	4.9	6.6	2.9	3.8	1.7	2.3	0.98	1.3	0.60	0.8	0.33	0.44	0.19	0.25	0.10	0.13	44.5	39.4
	20"	4.7	7	3	4.5	12	17	6.7	10	4.1	6.2	2.30	3.5	1.40	2.1	0.77	1.20	0.44	0.68	0.24	0.36	44.8	39.6
	15"	11	13	7.2	8.5	28	33	16	19	9.6	12	5.50	6.6	3.40	4.0	1.90	2.20	1.10	1.30	0.57	0.68	45.2	40.0
	10"	24	23	15	14	59	56	35	33	21	20	12.00	11.0	7.20	6.8	4.00	3.70	2.30	2.10	1.20	1.10	45.5	40.2
	5"	47	40	30	26	118	99	69	58	41	34	23.00	19.0	14.00	12.0	7.90	6.40	4.50	3.70	2.40	2.00	45.9	40.6



Exhausting

First determine:	Example
Suction load – scfm air (Q_s):	1.3 scfm
Suction pressure – inches Hg abs (h_s):	15"
Operating liquid pressure, psig (h_m):	60 psig
Discharge pressure, psig (h_d):	5 psig
(Refer to 1 ½ LM and ELL exhauster comparative performance chart).	

Step 1 - Locate appropriate suction pressure (in this case 15") on left side of chart and the line that applies to existing water pressure (in this case 60 psig).

Step 2 – Read across the 60 psig line to the 5 psig discharge pressure column noting

LM suction capacity:	1.4 scfm
ELL suction capacity:	3.1 scfm

Step 3 – Following along the same line you'll note

Operating water used:	28.3 gpm
-----------------------	----------

Step 4 – Since the ELL 1 ½ was the unit with the greater suction capacity in comparison to our requirement, we'll use it in computing the ideal capacity factor (C.F.).

$$\frac{\text{Desired capacity} - (1.3 \text{ scfm})}{\text{Suction capacity} - \text{ELL } 1 \frac{1}{2} (3.1 \text{ scfm})} = \frac{.419}{\text{(ideal C.F.)}}$$

Then using the capacity factor chart, find the size unit that provides a capacity factor that's equal to or greater than .419 (ideal C.F.)

The actual capacity of the selected unit is then determined by multiplying:

$$\begin{matrix} 3.1 \\ \text{(ELL } 1 \frac{1}{2} \text{ scfm} \\ \text{per chart)} \end{matrix} \times \begin{matrix} .613 \\ \text{(ELL } 1 \frac{1}{4} \\ \text{capacity factor)} \end{matrix} = 1.90 \text{ scfm}$$

Step 5 – To determine water consumption of the selected unity, multiply:

$$\begin{matrix} 28.3 \\ \text{(gpm operating} \\ \text{water used)} \end{matrix} \times \begin{matrix} .613 \\ \text{(Selected} \\ \text{unit C.F.)} \end{matrix} = 17.3 \text{ gpm}$$

Step 6 – In checking the capacity and consumption of the other unit considered, we find that the LM 1 ½, with a capacity of 1.4 scfm, has a water consumption rate of 28.3 gpm. It then becomes obvious that the ELL 1 ¼ is the best unit for this application as it delivers the greatest capacity with the least volume of water consumed.

**PENBERTHY SERIES LM, ELL, GL AND GH FOR PUMPING GASES
MODELS LM AND ELL - PERFORMANCE**

TABLE 5 - LM, ELL capacity factor

Size	Factor
½ A	0.030
½ B	0.047
½	0.121
¾	0.208
1	0.344
1¼	0.613
1½	1.000
2	1.820
2½	3.170
3	5.920
4	11.800
6	24.000
8	49.000
10	71.000
12	123.000

TABLE 6 - 1½ LM AND ELL EXHAUSTERS COMPARATIVE PERFORMANCE

Suction pressure Hg. Abs. (h _g)	Operating water pressure (h _m)	Suction capacity in scfm at discharge pressure below (Q _s)										Operating water gpm (Q _m)	
		0 psig		5 psig		10 psig		15 psig		20 psig			
		LM	ELL	LM	ELL	LM	ELL	LM	ELL	LM	ELL		
30* *	20	8.0	7.0	-	-	-	-	-	-	-	-	-	16.4
	40	10.0	9.0	2.5	5.0	-	-	-	-	-	-	-	22.5
	60	13.0	12.0	3.8	8.0	3.0	6.0	-	-	-	-	-	26.9
	80	14.0	13.0	5.5	10.0	3.9	8.5	3.2	7.2	2.9	-	-	30.6
	100	18.0	14.0	10.0	13.0	5.8	11.0	4.4	9.5	3.6	8.6	-	33.8
	140	19.0	18.0	13.0	16.0	8.5	15.0	6.2	14.0	5.6	13.0	-	39.2
25"	200	21.0	19.0	19.0	18.0	16.0	18.0	11.0	18.0	8.6	17.0	-	45.0
	20	1.6	3.0	-	-	-	-	-	-	-	-	-	17.2
	40	3.6	5.6	1.7	3.5	-	-	-	-	-	-	-	23.0
	60	5.8	8.0	2.8	5.9	2.2	4.6	-	-	-	-	-	27.3
	80	8.4	10.2	3.9	8.0	3.0	6.7	2.5	5.8	2.2	-	-	30.9
	100	9.9	11.4	6.1	10.0	4.1	9.0	3.4	7.9	3.0	7.3	-	34.0
20"	140	12.6	14.5	8.4	13.7	6.1	13.0	5.0	11.9	4.5	11.2	-	39.4
	200	16.7	17.4	14.3	17.0	10.7	16.8	8.7	16.1	6.9	15.7	-	45.1
	20	0.9	1.6	-	-	-	-	-	-	-	-	-	18.1
	40	1.9	3.6	1.2	2.4	-	-	-	-	-	-	-	23.6
	60	3.3	5.7	2.1	4.4	1.6	3.5	-	-	-	-	-	27.8
	80	4.9	7.8	2.8	6.3	2.3	5.2	1.9	4.6	1.6	-	-	31.3
15"	100	6.2	8.8	4.0	7.7	3.1	7.2	2.6	6.4	2.3	6.0	-	34.4
	140	8.9	11.3	5.6	10.8	4.4	10.2	3.8	9.6	3.4	9.1	-	39.6
	200	13.0	14.0	10.3	13.7	7.4	13.4	6.4	13.0	5.2	12.7	-	45.4
	20	0.5	0.8	-	-	-	-	-	-	-	-	-	18.8
	40	1.1	2.4	0.8	1.5	-	-	-	-	-	-	-	24.2
	60	1.8	3.9	1.4	3.1	1.1	2.6	-	-	-	-	-	28.3
10"	80	2.5	5.3	1.9	4.9	1.6	3.8	1.4	3.5	1.1	-	-	31.7
	100	3.7	6.3	2.5	5.9	2.2	5.4	1.9	5.0	1.6	4.6	-	34.7
	140	5.3	8.4	3.4	8.0	3.0	7.6	2.6	7.3	2.4	7.1	-	40.0
	200	8.8	10.5	6.5	10.3	4.8	10.1	4.3	9.9	3.6	9.7	-	45.7
	40	0.6	1.3	0.5	-	-	-	-	-	-	-	-	24.7
	60	0.9	2.6	0.8	2.0	0.7	1.5	-	-	-	-	-	28.7
5"	80	1.3	3.5	1.2	3.0	1.0	2.7	0.9	2.4	0.7	-	-	32.1
	100	2.0	3.9	1.4	3.8	1.3	3.7	1.2	3.5	1.1	3.3	-	35.1
	140	2.6	5.9	2.0	5.6	1.8	5.4	1.6	5.3	1.4	5.3	-	40.2
	200	5.1	7.0	3.7	6.9	2.8	6.8	2.4	6.7	2.2	6.6	-	45.9
	40	0.3	0.6	0.3	-	-	-	-	-	-	-	-	25.3
	60	0.4	1.6	0.3	1.2	0.3	-	-	-	-	-	-	29.2
5"	80	0.7	2.0	0.5	1.7	0.5	1.5	0.4	1.0	0.2	-	-	32.5
	100	0.8	2.2	0.6	2.1	0.6	2.1	0.6	2.0	0.6	1.9	-	35.4
	140	1.2	3.1	1.0	3.0	0.8	2.9	0.8	2.9	0.8	2.9	-	40.6
	200	2.0	3.5	1.5	3.5	1.2	3.5	0.9	3.5	0.9	3.5	-	46.2

* atmospheric



**PENBERTHY SERIES LM, ELL, GL AND GH FOR PUMPING GASES
MODELS LM AND ELL- DIMENSIONS**

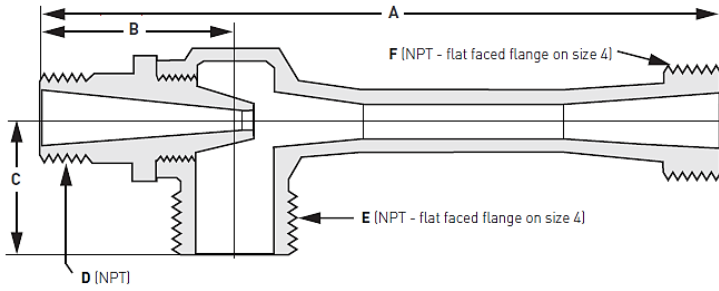

TABLE 10 - CAST LM, ELL

Size	Model	A	B	C	D	E	F
1/2 A	LM	4 3/8	1 1/2	1 1/4	1/4	1/2	1/2
1/2 B	LM, ELL	4 3/8	1 1/2	1 1/4	1/4	1/2	1/2
1/2	LM, ELL	4 1/2	1 5/8	1 1/4	3/8	1/2	1/2
3/4	LM, ELL	5 7/8	2	1 1/2	1/2	3/4	3/4
1	LM, ELL	7 1/8	2 1/4	1 3/4	3/4	1	1
1 1/4	LM, ELL	9	2 1/2	2 1/4	1	1 1/4	1 1/4
1 1/2	LM, ELL	11	2 3/4	2 1/2	1	1 1/2	1 1/2
2	LM, ELL	14 3/8	3 1/8	3	1 1/4	2	2
2 1/2	LM, ELL	18 1/8	3 1/2	4 1/8	1 1/2	2 1/2	2 1/2
3	LM, ELL	23 3/8	4	5	2	3	3
4	LM, ELL	32 7/8	5	6	3	4	4

❖ Flange. Bolting corresponds to CL50 flange per ASME B16.5

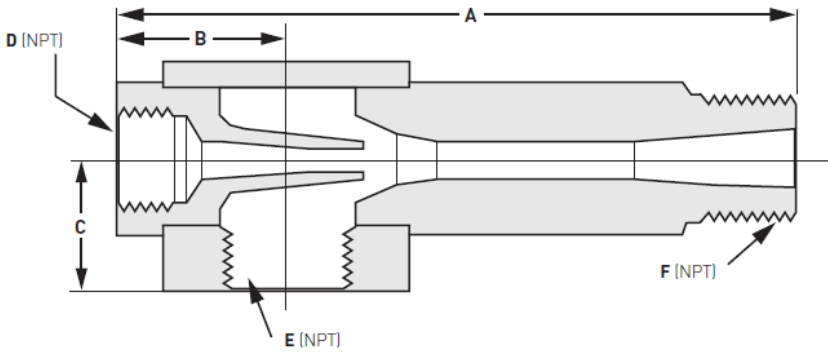

TABLE 11 - PVC LM, ELL

Size	Model	A	B	C	D	E	F
1/2 A	LM	3 3/4	1 11/16	1 5/16	1/4	1/2	1/2
1/2 B	LM	3 3/4	1 11/16	1 5/16	1/4	1/2	1/2
1/2	LM	4 5/8	1 11/16	1 5/16	1/4	1/2	1/2
3/4	LM	5 3/4	1 7/8	1	1/2	3/4	3/4
1	LM, ELL	6 7/8	2 1/8	1 5/16	3/4	1	1
1 1/4	LM, ELL	9 1/16	2 3/4	1 1/2	1	1 1/4	1 1/4
1 1/2	LM, ELL	10 15/16	3	1 3/4	1	1 1/2	1 1/2
2	LM, ELL	14 3/16	3 1/2	1 15/16	1 1/4	2	2
2 1/2	LM, ELL	18 1/2	4	2 1/2	1 1/2	2 1/2	2 1/2
3	LM, ELL	24 3/16	4 1/2	3	2	3	3

**PENBERTHY SERIES LM, ELL, GL AND GH FOR PUMPING GASES
MODELS LM AND ELL- DIMENSIONS**

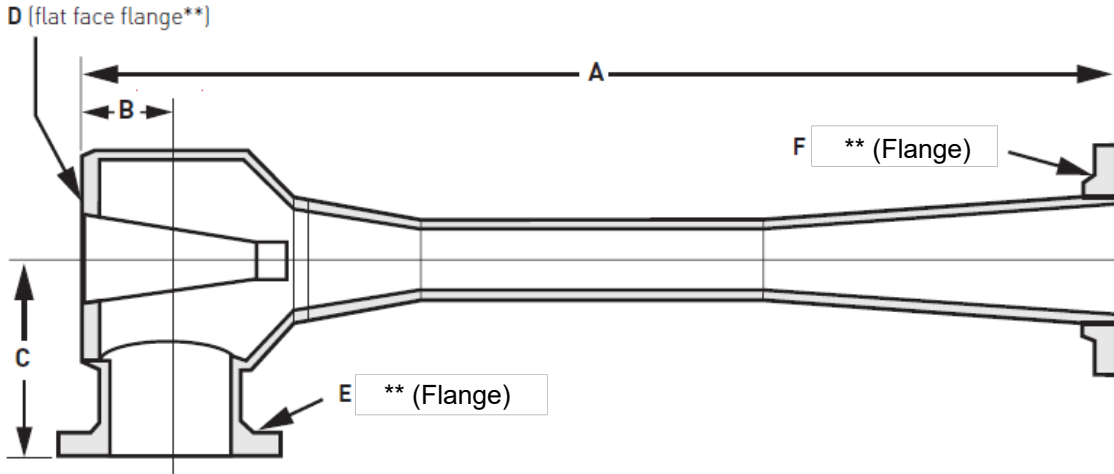

TABLE 12 - FABRICATED LM, ELL

Size	A	B	C	D**	E**	F**
4	38 $\frac{1}{4}$	5 $\frac{1}{4}$	8	3	4	4
6	52 $\frac{7}{8}$	5 $\frac{7}{8}$	9 $\frac{1}{2}$	4	6	6
8	74 $\frac{7}{16}$	8 $\frac{7}{16}$	13	6	8	8
10	87 $\frac{3}{8}$	10 $\frac{3}{8}$	14	8	10	10
12	110 $\frac{3}{4}$	11 $\frac{3}{4}$	18	10	12	12

** Bolting corresponds to CL150 flange per ASME B16.5. Bolt holes in D flange of all sizes are blind tapped.

PUMPING GASES USING STEAM OR AIR OPERATING MEDIUM

Series G jet pumps include the GL and GH models. They are used for exhausting, evacuating and priming applications.

Model GL uses operating steam or air from 60 to 120 psig. The maximum vacuum with closed suction is 6" Hg abs.

Model GH uses operating steam or air from 20 to 80 psig. The maximum vacuum with closes suction is 6 ½" Hg abs.

Each model is available in 15 sizes from ½" to 12" suction and discharge. Units are cast construction in sizes ½ through 6. Size 4 through 12 are available with fabricated construction. Certain sizes of units are also available in PVC or other polymer constructions.

NOTE: Always specify material, model and unit size when ordering.

TABLE 15 – MODEL CONSTRUCTION DATA

Model	GL, GH	Standard Materials
Sizes available	1/2A - 4"	Cast: Bronze, Carbon steel, 316 STS
	4" and up	Fabricated: Carbon steel, 316 STS
	1/2A - 3"	Non-Metallic: PVC, PP, PVDF

The capacities of both models are slightly higher when using air as the operating medium instead of steam. The following information is required for selection of both the GL and GH models for exhausting, evacuating and priming:

Exhausting

- Suction load, standard cubic feet per minute (scfm) air (Q_s)*
- Suction pressure, inches Hg. abs (h_s)
- Operating steam or air pressure, psig (h_m)
- Discharge pressure required, psig (h_d)
- For suction loads other than air, refer to dry air equivalent section on page 17.

Evacuating

- Suction load, in cubic feet of space to be evacuated
- Required time to evacuate, in minutes
- Operating steam or air pressure, psig (h_m)
- Final suction pressure, inches Hg abs. (h_s)
- Discharge pressure required, psig (h_d)

Priming

The selection procedure for ejectors in priming applications is the same as that for evacuation, except: The evacuation time must be doubled for priming applications because the priming capacity of any given ejector is half that of the evacuating capacity.

G SERIES UNIT SELECTION USING PERFORMANCE CHARTS

The following procedures and examples are included for selecting Series G jet pumps. Refer to the performance curves and tables when determining individual unit sizes.

For air operating medium, use the same performance data as for steam. To estimate the air consumption in standard cubic ft/minute, divide the listed values by 3. For example: The GH- 1 ½ steam consumption is 497 lbs/hr at 60 psig. The air consumption at the same pressure would be $497 \div 3 = 166$ scfm.

Exhausting – selection procedure

Step 1 – From the family of performance curves, select the one matching the available operating pressure, psig (h_m) and required discharge pressure, psig (h_d).

Step 2 – At the point where this curve intersects the suction pressure (h_s), read down the line to determine suction capacity (Q_s) of 1 ½" unit.

Step 3 – Compute ideal capacity factor (C.F.) by dividing:

$$\frac{Q_s - \text{required}}{Q_s - \text{from curve}}$$

Step 4 – Select (from C.F. chart) the unit having C.F. equal or greater than that determined in Step 3.

Step 5 – To figure steam consumption, refer to steam consumption table. Find the consumption listed for available operating pressure (h_m) and multiply by the C.F. for the selected unit.

Exhausting – Example

To exhaust 200 scfm:

Solution pressure, inches Hg abs. (h_s):	20
Operating steam pressure, psig (h_m):	80
Maximum discharge pressure, psig (h_d):	5

Both GL and GH Models are considered in this example to illustrate selection on the basis of operating economy.

Step 1 – Go to the 80 psig curves (h_m) and note discharge pressure of each.

Step 2 – These curves intersect suction pressures (h_s) at:

- 35.5 scfm on the GL – 1 ½ curve
- 17.0 scfm on the GH – 1 ½ curve

Step 3 – Ideal capacity factor (CF)

$$\frac{Q_s - \text{required}}{Q_s - \text{from curve}}$$

$$GL - 1 \frac{1}{2} = \frac{200}{35.5} = 5.63$$

$$GH - 1 \frac{1}{2} = \frac{200}{17.0} = 11.76$$

Step 4 – From the CF chart

- GL – 3 = 5.92
- GH – 4 = 11.8

Step 5 – To determine the most economical model of those considered, check steam consumption chart and determine the steam consumption of both under available operating pressure 80 psig:

GL – 3 uses 277 lbs/hr x CF 5.92 = 1640 lbs/hr.

Maximum discharge pressure (from curve) = 6 psig

GH – 4 uses 623 lbs/hr x CF 11.8 = 7351 lbs/hr

Maximum discharge pressure (from curve) = 21 psig

Therefore: the GL-3, having the lower steam consumption, in the desired range of operation, is the correct unit.

NOTE

GL and GH PVC units are for air operation only.

Evacuating – selection procedure

Step 1 – Compute time in minutes per hundred cubic feet to complete the required evacuation.

Step 2 – Refer to the GL, GH evacuation time chart. Find the operating pressure (h_m) and suction pressure (h_s).

Step 3 – Read across to the right and find the unit that will complete the evacuation within the desired time.

Step 4 – To figure steam consumption, multiply the steam used (shown in the right-hand column of the same chart) by the appropriate capacity factor (C.F.).

Evacuating – example

To evacuate 200 cubic feet in 30 minutes:

Final suction pressure, inches Hg abs. (h_s):	10
Operating steam pressure, psig (h_m):	40
Discharge pressure (h_d):	atmospheric

Step 1 – Determine time in minutes per 100 cubic feet to complete evacuation:

$$\frac{30 \text{ minutes total}}{2 \text{ (hundred ft}^3\text{)}} = 15 \text{ minutes per 100 cubic feet}$$

Step 2 – Locate operating steam pressure, 40 psig (h_m) and suction pressure, 10 inches Hg. abs. (h_s) on evacuation time chart.

Step 3 – Read across to the right and locate unit that will complete evacuation in desired time. The GH-1 will complete the evacuation in 14 minutes.

Step 4 – Find steam used in right-hand column – 366 lbs/hr

Multiply this by the C.F. for the GH-1:
 $.344 \times 366 \text{ lbs/hr} = 126 \text{ lbs/hr}$

**PENBERTHY SERIES LM, ELL, GL AND GH FOR PUMPING GASES
MODELS GL, GH - PERFORMANCE**

TABLE 16 - GL, GH EVACUATION TIME

Operating water pressure (hm) psig	Suction pressure, in. Hg abs (hs)	Time in minutes per																Operating steam used, lbs/hr (Q _m)					
		10 cubic feet evacuated				100 cubic feet evacuated																	
		1/8" A		1/8" B		1/4"		1/2"		1"		1 1/4"		1 1/2"		2"		2 1/2"		3"		1 1/2"	
GL	GH	GL	GH	GL	GH	GL	GH	GL	GH	GL	GH	GL	GH	GL	GH	GL	GH	GL	GH	GL	GH		
30	25"	-	2.4	-	1.5	-	6.0	-	3.5	-	2.1	-	1.20	-	0.73	-	0.40	-	0.23	-	0.12	-	301
	20"	-	4.7	-	3.0	-	12.0	-	6.7	-	4.1	-	2.30	-	1.40	-	0.77	-	0.44	-	0.24	-	301
	15"	-	8.7	-	5.5	-	21.0	-	12.0	-	7.5	-	4.20	-	2.60	-	1.40	-	0.82	-	0.44	-	301
	10"	-	15.0	-	9.6	-	37.0	-	22.0	-	13.0	-	7.30	-	4.50	-	2.50	-	1.40	-	0.76	-	301
40	25"	-	1.7	-	1.1	-	4.1	-	2.4	-	1.4	-	0.81	-	0.50	-	0.27	-	0.16	-	0.08	-	366
	20"	-	4.0	-	2.5	-	9.9	-	5.8	-	3.5	-	2.00	-	1.20	-	0.66	-	0.38	-	0.20	-	366
	15"	-	8.3	-	5.3	-	21.0	-	12.0	-	7.3	-	4.10	-	2.50	-	1.40	-	0.79	-	0.42	-	366
	10"	-	15.7	-	10.0	-	39.0	-	23.0	-	14.0	-	7.70	-	4.70	-	2.60	-	1.50	-	0.79	-	366
60	25"	1.0	1.7	0.64	1.1	2.5	4.1	1.4	2.4	0.87	1.4	0.49	0.81	0.3	0.50	0.16	0.27	0.09	0.16	0.05	0.08	221	497
	20"	2.3	4.7	1.50	3.0	5.8	12.0	3.4	6.7	2.00	4.1	1.10	2.30	0.7	1.40	0.38	0.77	0.22	0.44	0.12	0.24	221	497
	15"	4.0	9.3	2.50	6.0	9.9	23.0	5.8	13.0	3.50	8.1	1.90	4.60	1.2	2.80	0.66	1.50	0.38	0.88	0.20	0.47	221	497
	10"	7.7	19.0	4.90	12.0	19.0	47.0	11.0	27.0	6.70	17.0	3.70	9.30	2.3	5.70	1.30	3.10	0.72	1.80	0.39	0.96	221	497
80	25"	1.0	2.0	0.64	1.3	2.5	5.0	1.4	2.9	0.87	1.7	0.49	0.98	0.3	0.60	0.16	0.33	0.09	0.19	0.05	0.10	277	623
	20"	2.0	5.0	1.30	3.2	5.0	12.0	2.9	7.2	1.70	4.4	0.98	2.40	0.6	1.50	0.33	0.82	0.19	0.47	0.10	0.25	277	623
	15"	4.0	9.7	2.50	6.2	9.9	24.0	5.8	14.0	3.50	8.4	2.00	4.70	1.2	2.90	0.66	1.60	0.38	0.91	0.20	0.49	277	623
	10"	8.0	20.0	5.10	13.0	20.0	50.0	11.0	29.0	7.00	17.0	3.90	9.80	2.4	6.00	1.30	3.30	0.76	1.90	0.40	1.00	277	623
100	25"	1.0	2.0	0.64	1.3	2.5	5.0	1.4	2.9	0.87	1.7	0.49	0.98	0.3	0.60	0.16	0.33	0.09	0.19	0.05	0.10	333	750
	20"	2.3	5.3	1.50	3.4	5.8	13.0	3.4	7.7	2.00	4.6	1.10	2.60	0.7	1.60	0.38	0.88	0.22	0.50	0.12	0.27	333	750
	15"	4.7	12.0	3.00	7.4	12.0	29.0	6.7	17.0	4.10	10.0	2.30	5.70	1.4	3.50	0.77	1.90	0.44	1.10	0.24	0.59	333	750
	10"	8.7	40.0	5.50	26.0	21.0	99.0	12.0	58.0	7.60	35.0	4.30	-	2.6	-	1.40	6.60	0.82	3.80	0.44	2.00	333	750
120	25"	1.0	-	0.64	-	2.5	-	1.4	-	0.87	-	0.49	-	0.3	-	0.16	-	0.09	-	0.05	-	390	-
	20"	2.7	-	1.70	-	6.6	-	3.8	-	2.30	-	1.30	-	0.8	-	0.44	-	0.25	-	0.13	-	390	-
	15"	5.3	-	3.40	-	13.0	-	7.7	-	4.60	-	2.60	-	1.6	-	0.88	-	0.50	-	0.27	-	390	-
	10"	9.0	-	5.70	-	22.0	-	13.0	-	7.80	-	4.40	-	2.7	-	1.50	-	0.85	-	0.46	-	390	-

TABLE 17 - 1 1/2 GL, GH STEAM CONSUMPTION (lbs/hr Q_m)

Steam pres. (hm)	20	40	60	80	100	120	150
GL			221	277	333	390	474
GH	236	366	497	623	750	878	1067

TABLE 18 - GL, GH capacity factor

Size	Factor
1/8 A	0.030
1/8 B	0.047
1/4	0.121
3/8	0.208
1	0.344
1 1/4	0.613
1 1/2	1.000
2	1.820
2 1/2	3.170
3	5.920
4	11.800
6	24.000
8	49.000
10	71.000
12	123.000

TABLE 19 - 1 1/2 GL, GH AIR CONSUMPTION (scfm)

Air pres. (hm)	20	40	60	80	100	120	150
GL			74	92	111	130	158
GH	78	122	166	208	250	293	356



**PENBERTHY SERIES LM, ELL, GL AND GH FOR PUMPING GASES
MODELS GL, GH - PERFORMANCE**

1½ GL, GH SUCTION AIR LOAD SCFM (Qs) PERFORMANCE CURVES (EXHAUSTING)

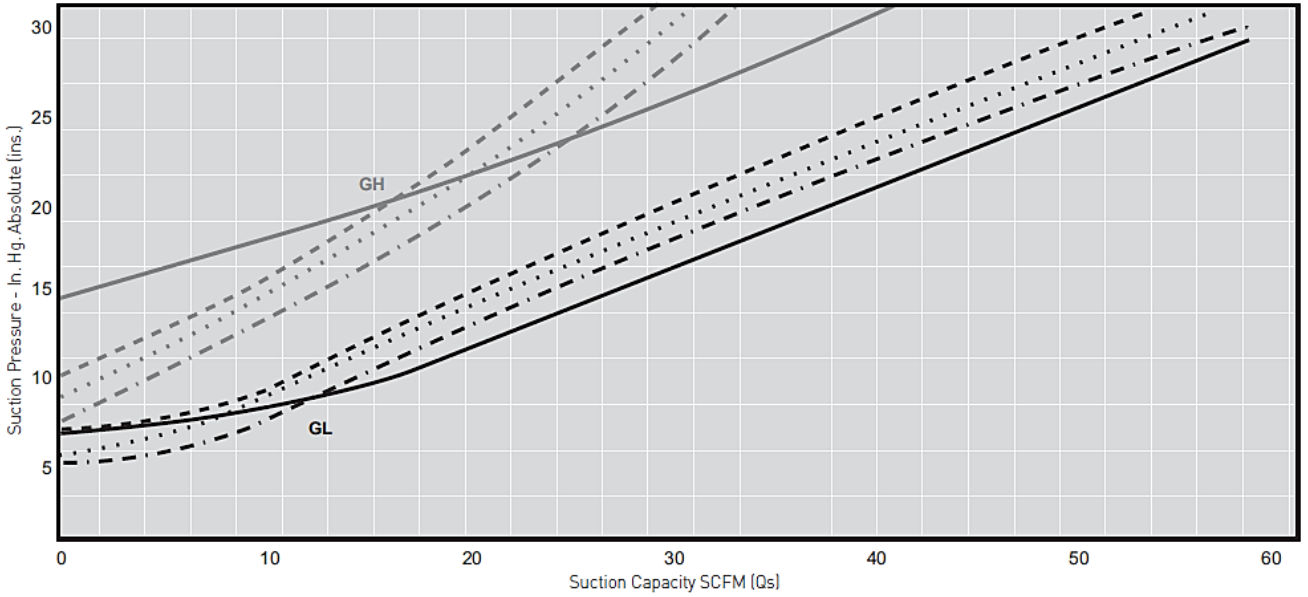

- GH**
- 80 psig O.P. with up to 21 psig D.P.
 - 60 psig O.P. with up to 14 psig D.P.
 - .-.- 40 psig O.P. with up to 6 psig D.P.
 - 20 psig Operating Pressure (hm) with 0 psig Discharge Pressure (hd)

- GL**
- 120 psig Operating Pressure (hm) with up to 12 psig Discharge Pressure
 - 100 psig O.P. with up to 9 psig D.P.
 - .-.- 80 psig O.P. with up to 6 psig D.P.
 - 60 psig O.P. with up to 1 psig D.P.

**PENBERTHY SERIES LM, ELL, GL AND GH FOR PUMPING GASES
MODELS GL, GH - DIMENSIONS**

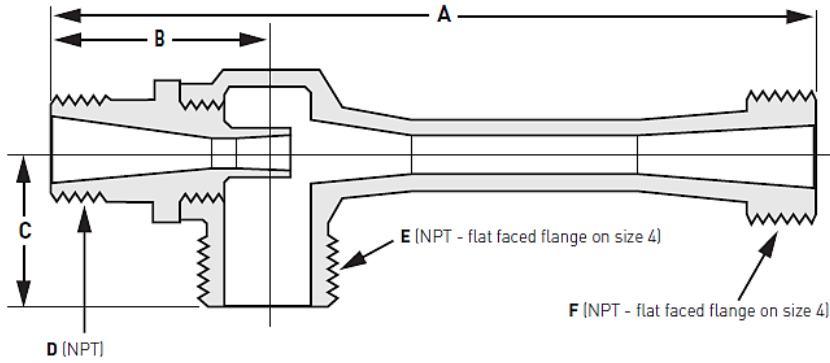

TABLE 20 - Cast GL, GH dimensions (in inches)

Size	A	B	C	D*	E*	F*
1/2 A	4 3/8	1 1/2	1 1/4	1/4	1/2	1/2
1/2 B	4 3/8	1 1/2	1 1/4	1/4	1/2	1/2
1/2	4 1/2	1 3/8	1 1/4	3/8	1/2	1/2
3/4	5 7/8	2	1 1/2	1/2	3/4	3/4
1	7 1/8	2 1/4	1 3/4	3/4	1	1
1 1/4	9	2 1/2	2 1/4	1	1 1/4	1 1/4
1 1/2	11	2 3/4	2 1/2	1	1 1/2	1 1/2
2	14 3/8	3 1/8	3	1 1/4	2	2
2 1/2	18 1/8	3 1/2	4 1/8	1 1/2	2 1/2	2 1/2
3	23 7/8	4	5	2	3	3
4	32 7/8	5	6	3	4 1/2*	4 1/2*

* Flange.

* Bolting corresponds to CL150 flange per ASME B16.5.

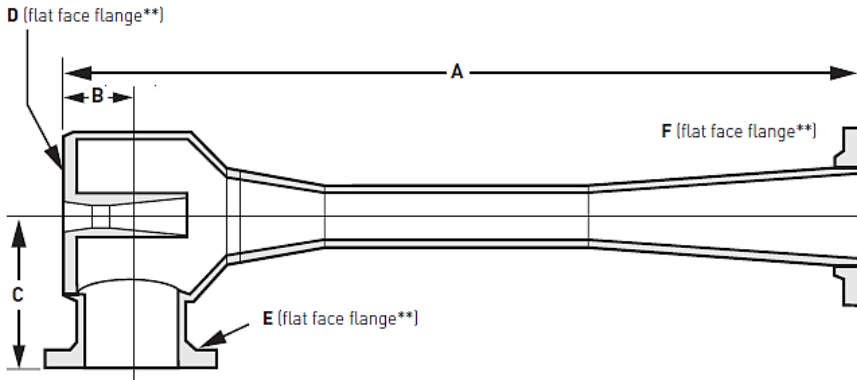

TABLE 21 - Fabricated GL, GH dimensions (in inches)

Size	A	B	C	D**	E**	F**
4	38 1/4	5 1/4	8	3	4	4
6	52 7/8	5 7/8	9 1/2	4	6	6
8	74 7/16	8 7/16	13	6	8	8
10	87 3/8	10 3/8	14	8	10	10
12	110 3/4	11 3/4	18	10	12	12

** Bolting corresponds to CL150 flange per ASME B16.5. Bolt holes in D flange of all sizes are blind tapped.

**PENBERTHY SERIES LM, ELL, GL AND GH FOR PUMPING GASES
MODELS GL, GH - DIMENSIONS**

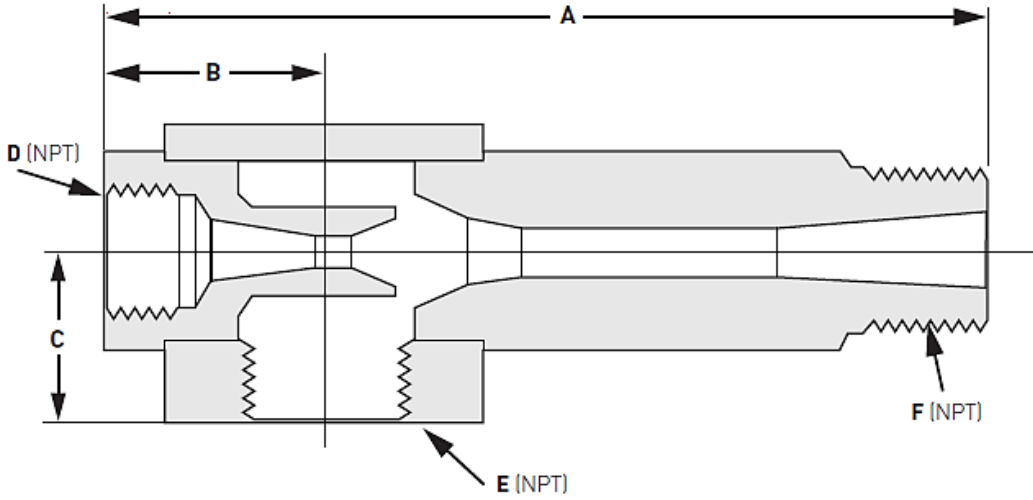

TABLE 22 - PVC GL, GH - for air operation only dimensions (in inches)

Size	A	B	C	D	E	F
1/2 A	3 3/4	1 11/16	15/16	1/4	1/2	1/2
1/2 B	3 3/4	1 11/16	15/16	1/4	1/2	1/2
1/2	4 5/8	1 11/16	15/16	1/4	1/2	1/2
3/4	5 3/4	1 7/8	1	1/2	3/4	3/4
1	6 7/8	2 1/8	15/16	3/4	1	1
1 1/4	9 1/16	2 3/4	1 1/2	1	1 1/4	1 1/4
1 1/2	10 15/16	3	1 3/4	1	1 1/2	1 1/2
2	14 7/16	3 1/2	1 15/16	1 1/4	2	2
2 1/2	18 1/2	4	2 1/2	1 1/2	2 1/2	2 1/2
3	24 7/16	4 1/2	3	2	3	3

**PENBERTHY SERIES LM, ELL, GL AND GH FOR PUMPING GASES
MODELS GL, GH - SELECTION**

PART NUMBER FOR NPT UNITS EXTENDED PART NUMBER FOR FLANGED UNITS



Connections: NPT (Standard)

Model	Code
LL	PLL-
LM	PLM-
LH	PLH-
GL	PGL-
GH	PGH-
ELL	PELL-
HLM	PHLM-
RJ	PRJ-

Flanged

Model Code Suffix

F

Example: PLLF-

** 4" body is cast with flanges

-> use "F" only w/ flanged nozzle

Motive	Suction	Outlet																				
(use letter codes from table)																						
<table border="1"> <thead> <tr> <th>Size</th> <th>Letter Code</th> </tr> </thead> <tbody> <tr><td>1/2"</td><td>D</td></tr> <tr><td>3/4"</td><td>E</td></tr> <tr><td>1"</td><td>F</td></tr> <tr><td>1 1/4"</td><td>G</td></tr> <tr><td>1 1/2"</td><td>H</td></tr> <tr><td>2"</td><td>I</td></tr> <tr><td>2-1/2"</td><td>J</td></tr> <tr><td>3"</td><td>K</td></tr> <tr><td>4"</td><td>L</td></tr> </tbody> </table>			Size	Letter Code	1/2"	D	3/4"	E	1"	F	1 1/4"	G	1 1/2"	H	2"	I	2-1/2"	J	3"	K	4"	L
Size	Letter Code																					
1/2"	D																					
3/4"	E																					
1"	F																					
1 1/4"	G																					
1 1/2"	H																					
2"	I																					
2-1/2"	J																					
3"	K																					
4"	L																					

Size	Code	Size	Code	Size	Code	Size	Code	Size	Code	Size	Code
1/2A	08A	1/2"	08	1"	12	1 1/2"	16	2 1/2"	20	4" **	24
1/2B	08B	3/4"	10	1 1/4"	14	2"	18	3"	22		

Note: Unit size is dictated by the body size. Standard units have the suction and outlet the same size.

Body Material	Code	Special Materials	Code	Plastic Materials	Code
Carbon Steel (WCB)	C	Hastelloy C (CW12MW)	H	PVC	P
316 SS (CF8M)	S	Alloy 20 (CN7M)	A	CPVC	CP
Bronze (B62)	B	Monel (M-35-1)	M	Polypropylene	PP
				PVDF (formerly Kynar)	K

Flange Style	Code
Weld Neck Flange	W
Slip-on Flange	

W = standard configuration

Note: Part combinations that cannot be defined here will be designated as "Special" and will have either an order based part number or a base part with "SP" included in the part number.

Flange Class	Code
CL150 ASME (B16.5)	(Blank)
CL300 ASME (B16.5)	3

Examples:

- 3/4" Model LM in bronze, standard connections
Part number: **PLM-10-B**
- 1-1/2" Model LH in carbon steel with CL150 flanges, WN style, with standard 1-1/4" x 1-1/2" x 1-1/2" connection sizes
Part number: **PLHJ-16-C-W-GHH**
- 2" Model GL in 316SS with CL300 flanges, WN style, with standard 1-1/2" x 2" x 2" connection sizes
Part number: **PGLF-18-S-W3-HII**
- 4" Model LM in carbon steel with standard NPT nozzle and CL150 flanged body (which is the only CL available for 4" body)
Part number: **PLM-24-C**
- 4" Model LM in carbon steel with flanged nozzle and CL150 flanged body (which is the only CL available for 4" body)
Part number: **PLMF-24-C-W-KLL**



**PENBERTHY SERIES LM, ELL, GL AND GH FOR PUMPING GASES
MODELS GL, GH, U, L, 2NC**

DRY AIR EQUIVALENT (DAE) CONVERSIONS FOR GL AND GH MODELS

Performance curves for Penberthy steam-air ejectors are plotted in terms of suction pressure and suction gas flow, lb/hr 70°F dry air equivalent (DAE).

Most ejector application data does not include suction gas rate as lb/hr 70°F dry air equivalent, but rather the suction gas rate is presented at some other temperature and for some gas or combination of gases of a composition different from that of air.

Since it is not practical for a manufacturer of steam jet ejectors to maintain facilities for testing ejectors with all the numerous suction gas mixtures and all the many temperatures for which ejectors are used, a method has been devised to permit the design and test of ejectors using air at normal room temperatures or air and steam at any temperature convenient for the manufacturer. The Heat Exchange Institute (HEI) provides a standard that describes the method that is used and accepted by manufacturers and users of ejectors. Material used in this explanation is adapted from the 'Standards for Steam Jet Ejectors' as published by the HEI.

It is important for all persons involved in the application of Penberthy ejectors to be conversant with the method of changing any load gas to its dry air equivalent at 70°F.

To determine average molecular weight

Gas mixtures are presented in terms of lb/hr or can be converted to these terms. Steam or water vapor may be contained in a mixture of gases and vapors, however it is treated as a separate component because temperature correction is different from that of other gases. The following example illustrates the most complex conversion that one might encounter:

Given: 100 lb/hr of mixture of gases and vapor at 200°F temperature, consisting of 20 lb/hr of carbon dioxide gas, 30 lb/hr of air, 5 lb/hr of hydrogen and 45 lb/hr of water vapor.

Molecular weights are as follows:

CO₂ = 44 lb/mol

Air = 29 lb/mol

H₂ = 2 lb/mol

H₂O = 18 lb/mol

Find average molecular weight of the mixture except for water vapor:

20	lb/hr CO ₂	÷	44	lb/mol	=	0.455	mol/hr
30	lb/hr Air	÷	29	lb/mol	=	1.035	mol/hr
5	lb/hr H ₂	÷	2	lb/mol	=	2.500	mol/hr
<hr/>							
55	Lb/hr Mixture					3.990	mol/hr

$$\text{Avg. m.w.} = \frac{55 \text{ lb/hr}}{3.99 \text{ mol/hr}} = 13.8 \text{ lb/mol}$$

Molecular weight conversion factors (29 mw = 1.0)

Use same gas as given above and curve no. 1:

C_{mw} correction factor for 13.8 mw = 0.7

C_{mw} correction factor for 18 (H₂O) = 0.81

Temperature conversion factors (70°F = 1.0)

Use same gas as above and curve no. 2.

C_t temperature correction for 13.8 mw gas at 200°F (use curve for air) = 0.968

C_t temperature correction for steam at 200°F = 0.957

Actual conversion

Use factors from above as follows to find the 70°F dry air equivalent of 100 lb/hr of a mixture of gas and water vapor all at 200°F and consisting of 20 lb/hr of CO₂ plus 30 lb/hr of air plus 5 lb/hr of H₂ plus 45 lb/hr of H₂O.

$$\frac{(20 + 30 + 5)}{0.7 \times 0.968} + \frac{45}{0.81 \times 0.957} = 82 + 58 = 140 \text{ lb/hr}$$

Therefore an ejector that will pump the specified gas load of 100 lb/hr at 200°F must also be able to pump 140 lb/hr of air at 70°F.

NOTE: Do not confuse DAE with non-condensable gas load.



DRY AIR EQUIVALENT (DAE) CONVERSIONS FOR GL AND GH MODELS

TEMPERATURE ENTRAINMENT RATIO CURVE (NO. 2)*

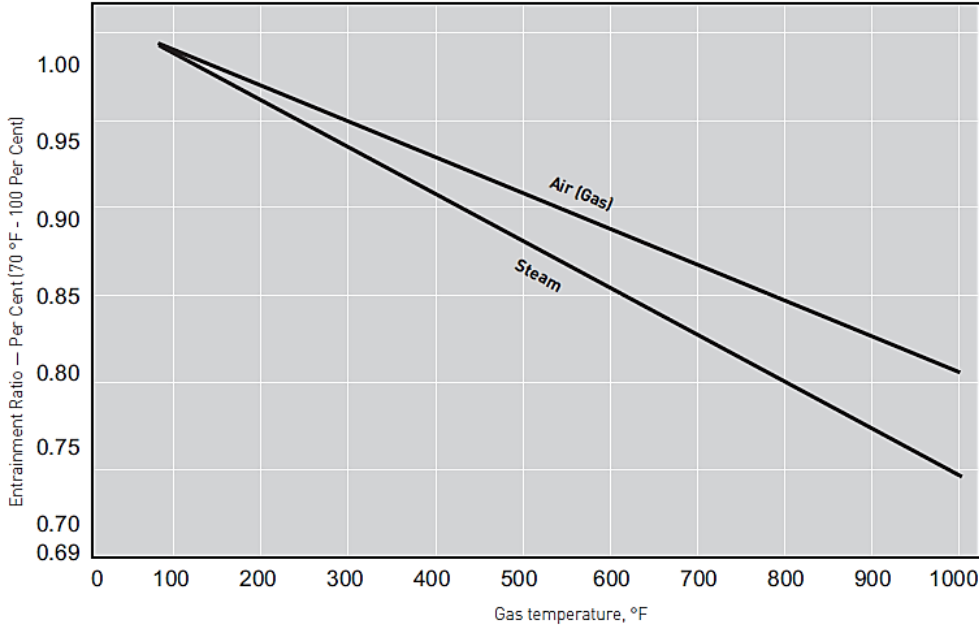

NOTE

Entrainment ratio is the ratio of the weight of air or steam at 70 °F temperature to the weight of air or steam at a higher temperature that would be handled by the same ejector operation under the exact same conditions

MOLECULAR WEIGHT ENTRAINMENT RATIO CURVE (NO. 1)*

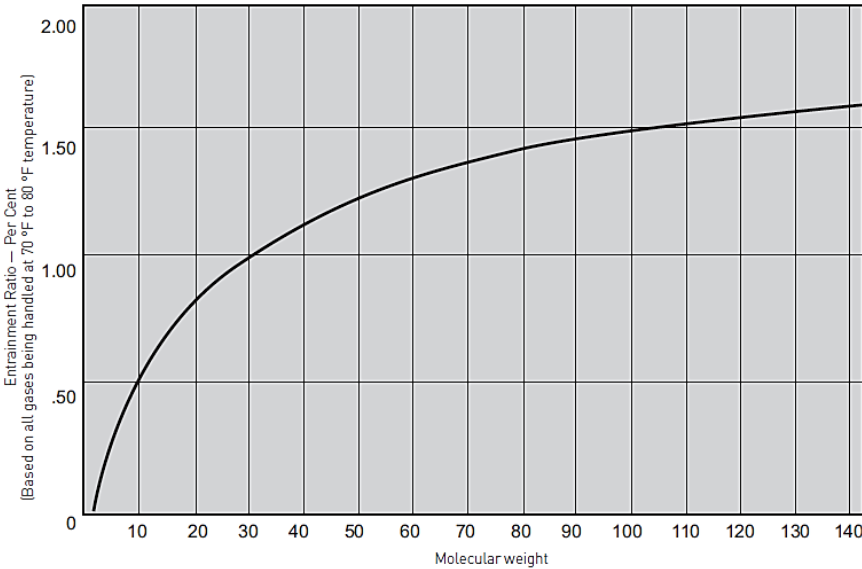

NOTE

Entrainment ratio is the ratio of the weight of gas handled to the weight of air that would be handled by the same ejector operation under the exact same conditions

*reprinted by permission of the Heat Exchange Institute.

Authorised Distributor:



**NATIONWIDE
OIL & GAS**

46, Jalan SS 22/21, Damansara Jaya,
47400 Petaling Jaya,
Selangor Darul Ehsan, Malaysia.

Email: nog@nog.com.my

Website: www.nog.com.my

PENBERTHY®

16633 Foltz Parkway, Strongsville, OH 44149 USA • Telephone: +440-572-1500
www.PenberthyProcess.com • sales@PenberthyProcess.com